

# NVMe Switch Adapter

**ARC-1389-32I**

(PCIe 5.0 x16 NVMe Switch Adapter)

## User Manual

Version: 1.7

Issue Date: April, 2026

## **Copyright and Trademarks**

The information regarding products in this manual is subject to change without prior notice and does not represent a commitment on the part of the vendor, who assumes no liability or responsibility for any errors that may appear in this manual. All brands and trademarks are the properties of their respective owners. This manual contains materials protected under International Copyright Conventions. All rights reserved. No part of this manual may be reproduced in any form or by any means, electronic or mechanical, including photocopying, without the written permission of the manufacturer and the author.

## **FCC Statement**

This equipment has been tested and found to comply with the limits for a Class B digital device, pursuant to part 15 of the FCC Rules. These limits are designed to provide reasonable protection against interference in a residential installation. This equipment generates, uses, and can radiate radio frequency energy and, if not installed and used in accordance with the instructions, may cause harmful interference to radio communications. However, there is no guarantee that interference will not occur in a particular installation.

## **Manufacturer's Declaration for CE Certification**

We confirm ARC-1389-32I has been tested and found compliant with the requirements in the council directive relating to the EMC Directive 2004/108/EC. Regarding to the electromagnetic compatibility, the following standards were applied:

EN 55022: 2006, Class B  
EN 61000-3-2: 2006  
EN 61000-3-3: 1995+A1: 2001+A2: 2005

EN 55024:1998+A1:2001=A2:2003  
IEC61000-4-2: 2001  
IEC61000-4-3: 2006  
IEC61000-4-4: 2004  
IEC61000-4-5: 2005  
IEC61000-4-6: 2006  
IEC61000-4-8: 2001  
IEC61000-4-11: 2004

# Contents

<b>1. Introduction .....</b>	<b>5</b>
1.1 Overview .....	5
1.2 Features .....	7
<b>2. Hardware Installation .....</b>	<b>10</b>
2.1 Before You First Installing.....	10
2.2 Board Layout.....	11
2.2.1 Top View Connectors.....	11
2.2.2 Connector Physical-to-Logical Mapping .....	12
2.2.3 MCIO Connector .....	12
2.3 Installation.....	14
2.4 Serial Interface Bus.....	18
2.5 Summary of the installation.....	20
<b>3. McBIOS Switch Setup Utility.....</b>	<b>22</b>
3.1 Main Menu .....	24
3.2 Physical Drives .....	25
3.2.1 Identify Selected Drive.....	25
3.3 Raid System Function .....	26
3.3.1 Mute The Alert Beeper .....	26
3.3.2 Alert Beeper Setting .....	27
3.3.3 Change Password .....	27
3.3.4 Controller Fan Detection .....	28
3.4 Ethernet Configuration.....	29
3.4.1 DHCP Function .....	29
3.4.2 Local IP address.....	30
3.4.3 HTTP Port Number .....	31
3.4.4 Telnet Port Number.....	31
3.4.5 SMTP Port Number .....	32
3.4.6 Ethernet Address.....	32
3.5 Alert By Mail Config.....	33
3.6 View System Events .....	35
3.7 Clear Events Buffer .....	35
3.8 Hardware Monitor .....	36
3.9 System Information .....	36
<b>4. ArchHTTP Proxy Server Installation .....</b>	<b>37</b>
4.1 For Windows.....	37
4.2 For Linux .....	43
4.3 For FreeBSD.....	45

4.4 ArcHTTP Configuration .....	47
• General Configuration .....	47
• Mail (Alert by Mail) Configuration .....	48
• SNMP Traps Configuration .....	49
• Rescan Device Configuration .....	51
• Collect Support Data .....	51
<b>5. Web Browser-based Configuration .....</b>	<b>52</b>
5.1 Start-up Switch Storage Manager .....	52
• Start-up from Windows Local Administration .....	52
• Start-up Switch Storage Manager from Linux/ FreeBSD Local Administration .....	53
• Start-up from Ethernet Port (Out-of-Band) .....	53
5.2 Switch Storage Manager .....	54
5.3 Main Menu .....	55
5.4 Physical Drive .....	55
5.4.1 Identify Drive .....	55
5.5 System Controls .....	56
5.5.1 System Config .....	56
• System Beeper Setting .....	56
5.5.2 Advanced Configuration.....	56
• PCIE Read Request Size .....	56
• PCIE Max Payload Size .....	56
• CPU Fan Control.....	57
• PCIE Host Speed .....	57
• PCIE Host ASPM.....	57
• NVMe SSD ASPM.....	58
• CNT#x Speed .....	58
5.5.3 Ethernet Configuration .....	58
• DHCP Function .....	59
• Local IP Address (Used If DHCP Disabled) .....	59
• Gateway IP Address (Used If DHCP Disabled).....	60
• Subnet Mask (Used If DHCP Disabled).....	60
• Telnet Port Number .....	60
• SMTP Port Number .....	61
5.5.4 Alert By Mail Configuration .....	61
5.5.5 SNMP Configuration .....	63
5.5.6 Time Zone Configuration .....	64
• NTP Server Address .....	66
• Time Zone.....	64
• Automatic Daylight Saving.....	64
5.5.7 View Events/Mute Beeper .....	65
5.5.8 Generate Test Event .....	65
5.5.9 Clear Events Buffer.....	65
5.5.10 Modify Password.....	66
5.5.11 Update Firmware .....	66

# INTRODUCTION

---

5.6 Information .....	67
5.6.1 Raid Set Hierarchy .....	67
5.6.2 System Information .....	67
5.6.3 Hardware Monitor .....	68
<b>Appendix A</b> .....	<b>69</b>
Upgrading Flash ROM Update Process .....	69
<b>Appendix B</b> .....	<b>73</b>
Event Notification Configurations .....	73
<b>Appendix C</b> .....	<b>74</b>
High Reliability .....	74
• Hard Drive Failure Prediction .....	74
Data Protection .....	74
• Recovery ROM .....	74

# INTRODUCTION

---

## 1. Introduction

This section presents a brief overview of NVMe switch adapters, PCIe Gen5 x16 ARC-1389-32I.

### 1.1 Overview

The ARC-1389-32I presents advanced Gen5 switch technology in enhanced performance using 4x MCIO ports (dedicated PCIe Gen5 x8 per MCIO) device interface. The switch adapter is designed with a high performance management engine and PCIe Gen 5.0 host/device interface, and supports internal synthetic switch mode, allowing customers to build high-bandwidth, low-latency, scalable, cost-effective and robust performance storage for ML/AI, HPC and enterprise applications

### NVMe Performance Gains for Fast Data

Based on Broadcom's 48-Channel PEX89048 switch chip that provides x16 lanes of dedicated PCIe Gen 5.0 upstream bandwidth and x4 lanes of dedicated downstream bandwidth to each device interface, ARC-1389-32I NVMe switch adapter raises the standard to higher performance levels with several enhancements including a new high performance management engine, outstanding performance PCIe Gen 5.0 host and PCIe Gen 5.0 (NVMe) interface bus interconnection. ARC-1389-32I provides an extremely fast, reliable and ultra-compact solution for companies that need storage and is especially designed for accelerated computing, ML/AI and HPC applications. This switch adapter can support up to 8x Gen5 x4 NVMe on just one PCIe adapter, increasing capacity and speed as more NVMe devices are added. The ARC-1389-32I supports 8x4, 16x2 or 32x1 NVMe SSD connect and combines them on a switch adapter for high-capacity, high-performance, low latency storage array environments.

### Unsurpassed Advantages

In Areca's high-performance PCIe switch solution, ARC-1389-32I brings PCIe NVMe to a superior performance switch adapter at an elevated throughput, and low latency. ARC-1389-32I hardware

# INTRODUCTION

---

secure boot helps ensure that the firmware code running on ARC-1389-32I hardware platforms is authentic and unmodified. During the adapter firmware upgrade process, it is possible for a problem to occur, resulting in corruption of the controller firmware. With our redundant flash image feature the adapter will revert back to the last known good firmware and continue operating. The ARC-1389-32I switch adapter includes several innovative features, including true surprise add and removal, Downstream Port Containment and Read Tracking, which can avoid typical situations that would cause a kernel panic or blue screen event. The firmware can monitor and check the current attached device status. It includes slot control capabilities, slot link status, transaction error count reports and device information. User can use it to test new designs or watch over active systems to prevent problems. Also, with LED status for each individual NVMe channel on the bracket is closely monitored to help your business continuity.

## **Maximum Interoperability**

The ARC-1389-32I switch adapter enables support for maximum interoperability using standard system UEFI secure boot and OS in-box NVMe driver. The in-box plug-and-play function allows automatic installation of the best-matched driver with no user intervention required for driver media insertion. The ARC-1389-32I supports in-box (native) NVMe driver for most major operating systems, including Windows, Linux, FreeBSD, VMare and more, along with key system monitoring features such as enclosure management, SMTP and SNMP functions. ARC-1389-32I products and technology are based on extensive testing and validation processes, optimizing switch adapter in field-proven compatibility with operating systems, motherboards and applications.

## **Intuitive Management Access**

Modern IT infrastructure relies heavily on efficient storage management to ensure optimal performance, reliability, and longevity of hardware components. Software management provides critical insights into adapter drive health, and predictive failure analysis. By leveraging these metrics, organizations can optimize storage efficiency, reduce downtime, and extend hardware lifespan. Similar to Areca switch adapter, the ARC-1389-32I switch adapter is sup-

# INTRODUCTION

---

plied with fully validated and supported firmware and in-band or out of band manageability features. McBIOS switch setup utility is a BIOS based utility used to simplify manage switch adapter. The switch adapter firmware contains a browser-based switch storage manager which can be accessed through the ArchHttp proxy server in Windows, Linux, FreeBSD and on-board Lan port. The switch storage manager allows local and remote to configure from standard web browser. The adapter also supports CLI and API libraries for custom configurations.

## 1.2 Features

### **Adapter Architecture**

- PEX89048 Gen5 Switch/High-performance management engine
- PCIe Gen5 x16 lane host interface
- Connection for up to 8x4, 16x2 and 32x1 NVMe SSD connect via direct cable or back/mid-plane
- Support 4x MCIO (PCIe Gen5 x8 per MCIO)
- Drive interface at each MCIO - PCIe Gen5 at 32GT/per lane
- Hardware secure boot
- Multi-adapter support for large storage requirements
- Delivers 64GB/s bandwidth & sustained transfer speeds up to 60GB/s
- Support SFF-9402 compliant connector pin-out
- Support backplanes based on the SFF-TA-1005 specification (UBM) and VPP

### **Firmware Features**

- SRIS and REFCLK support
- Downstream port containment
- Read tracking
- Surprise Add and Remove (Hot-Plug ) SSD support
- Synthetic Hierarchy generation
- Support for UEFI secure boot
- Redundant flash image for adapter availability
- NVRAM for switch adapter event & transaction log
- Web GUI device information(included S.M.A.R.T) via Archhttp utility inquiry from Host OS
- Support Out-of-Band PCIe VDM
- Flexible reconfiguration downstream station port widths: x1, x2, x4, x8, and x16 using GUI interface (update to ARC-1289-32I

# INTRODUCTION

---

firmware package)

## **Monitors/Notification**

- System status indication through alarm buzzer
- SMTP support for email notification
- Bracket LED for each NVMe activity/indetify status
- SNMP support for remote manager
- Support for multiple backplanes, including VPP and UBM
- Support slot link control capabilities, link status and error count monitoring

## **Switch Management**

- Field-upgradeable firmware in flash ROM
- UEFI OS to launch McBIOS switch setup utility
- Web browser-based switch storage manager via Archttp utility and on-board Lan port
- Support command-line interface (CLI)
- API library for developers to monitor switch adapters with their own utility
- Support Areca push button and LCD display panel module

## **OS Native NVMe Driver Support**

- OS native (in-box) NVMe driver support

<b>PCIe Gen5 x16 NVMe Switch Adapter</b>	
<b>Model Name</b>	ARC-1389-32I
<b>PCIe Switch</b>	PEX89048 Gen5 Switch/Management Engine
<b>Host Bus Type</b>	PCIe 5.0 x 16 Lanes
<b>Device Connector</b>	4x MCIO (PCIe 5.0 x8 per MCIO) Connector
<b>Form Factor (L x H)</b>	LP-MD2 : 64.41(H) x 167.65(L) mm
<b>Device Driver</b>	In-Box(Native) NVMe Driver
<b>Management Port</b>	In-Band: PCIe/Out-of_band:Lan Port and PCIe VDM
<b>Power Consumption</b>	Worst Case: 23.7 Watts, Typical: 18 Watts

# HARDWARE INSTALLATION

---

## 2. Hardware Installation

This section describes the procedures for installing the ARC-1389-32I switch adapters.

### 2.1 Before You First Installing

Thanks for purchasing the switch adapter as your data storage system. This user manual gives simple step-by-step instructions for installing and managing the switch adapter. To ensure personal safety and to protect your equipment and data, reading the following information package list carefully before you begin installing.

#### Package Contents

If your package is missing any of the items listed below, contact your local dealers before you install.

- 1 x ARC-1389-32I switch adapter with full-height profil bracket in an ESD-protective bag
- 1 x Low-profile bracket

#### System Requirement

The ARC-1389-32I switch adapter can be installed in an universal PCIe slot and requires a motherboard that:

ARC-1389-32I switch adapter requires:

- Comply with the PCIe 5.0 x16 lanes  
The adapter can work on the PCIe 5.0 x1, x4, x8, and x16 signal with x16 mechanical slot M/B.
- Backward-compatibe with PCIe 2.0/3.0/4.0
- It can auto configure to the slot speed and width.

#### Installation Tools

The following items may be needed to assist with installing the ARC-1389-32I switch adapter into an available PCIe slot.

- Small screwdriver
- Host system hardware manuals and manuals for the disk or enclosure being installed

# HARDWARE INSTALLATION

## 2.2 Board Layout

The ARC-1389-32I offers 4x MCIO (PCIe 5.0 x8 per MCIO connectors). This section provides the board layout and connector/LED for the switch adapter.

### 2.2.1 Top View Connectors

The following figure shows the key connectors of the ARC-1389-32I.

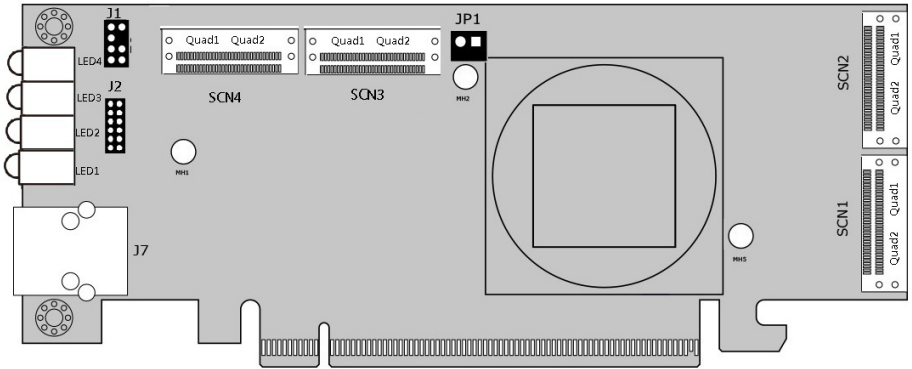

Figure 2-1, ARC-1389-32I Top View

Components	Description	Type
1. (J1)	I2C/LCD Control Function	7-pin Header
2. (JP1)	Fan Connector	2-pin Box Header
3. (SCN1)~(SCN4)	1. 4x MCIO[x8] (Dedicated PCIe 5.0 x8 per MCIO) for PCIE Device 2. A MCIO [x8] includes two quads (Quad1 and Quad2)	MCIO[x8] Connector
4. (LED1), (LED2), (LED3), (LED4)	SCN 1 ~ 4 Activity/Identify NVMe SSD LED for directly attach to adapter	Dual-Color LED
5. (J2)	Manufacturer Reserved	12-pin Header
6. (J7)	Lan Port	RJ45

Table 2-1, ARC-1389-32I Components

# HARDWARE INSTALLATION

The following table is the activity LED status behavior.

LED	Status	Indication
Green LED (Activity)	Off	There is not any I/O activity on that NVMe SSD.
	On (10 times/sec.)	There is a I/O activity on that NVMe SSD.
Red LED (Identify)	Off	This NVMe SSD is present and status is normal.
	On (6 times/ sec.)	Adapter is identifying this NVMe SSD.

## 2.2.2 Connector Physical-to-Logical Mapping

The following table shows the adapter’s physical connector to logical connector mapping as viewed from manager interface , when used with the switch manager. The adapter uses x8 MCIO connectors. Each connector is segregated into quads and mapped accordingly.

Physical Connector-to-Logical Connector Mapping			
Downstream Station	Adapter Label	Tool Mapping	Port Number
#2 (The PCIe switch groups 16 PCIe lanes into a station.)	SCN1(CNT#1)	Quad1	0~3
		Quad2	4~7
	SCN2(CNT#2)	Quad1	0~3
		Quad2	4~7
#1 (The PCIe switch groups 16 PCIe lanes into a station.)	SCN3(CNT#3)	Quad1	0~3
		Quad2	4~7
	SCN4(CNT#4)	Quad1	0~3
		Quad2	4~7

## 2.2.3 MCIO Connector

Mini Cool Edge (MCIO) Connectors offer increased flexibility by providing multiple circuit options and meet PCIe standards up to PCIe Generation 5 with high-speed data transmission rates. The following table defines the adapter’s internal x8 MCIO connector (PCIe 5.0 x8 per MCIO connectors) pinouts. The adapter follows the SFF-9402 standard for connector sideband signal assignments. Each x8 connector includes eight PCIe transmit and receive lanes, and two sets of sidebands designated as A and B, in accordance with the SFF-9402 specification. The following table defines the ARC-1389-32I MCIO connector pin definition.

# HARDWARE INSTALLATION

	MCIO x8 Connector Pin Definition (SFF-TA-1016)			
	Pin	Name	Name	Pin
(SCN1)~(SCN4) Defined IO	A1	GND	BND	B1
	A2	PERp0	PETp0	B2
	A3	PERn0	PETn0	B3
	A4	GND	GND	B4
	A5	PERp1	PETp1	B5
	A6	PERn1	PETn1	B6
	A7	GND	GND	B7
	A8	PA_AUX_3V3	MCIO_SCL_A	B8
	A9	N/C	MCIO_SDA_A	B9
	A10	GND	GND	B10
	A11	MCIO_CLK_A_Dp	PERSTNA_A_L3V3	B11
	A12	MCIO_CLK_A_Dn	PA_CBL_DET	B12
	A13	GND	GND	B13
	A14	PERp2	PETp2	B14
	A15	PERn2	PETn2	B15
	A16	GND	GND	B16
	A17	PERp3	PETp3	B17
	A18	PERn3	PETn3	B18
	A19	GND	GND	B19
	A20	PERp4	PETp4	B20
	A21	PERn4	PETn4	B21
	A22	GND	GND	B22
	A23	PERp5	PETp5	B23
	A24	PERn5	PETn5	B24
	A25	GND	GND	B25
	A26	PB_AUX_3V3	MCIO_SCL_B	B26
	A27	N/C	MCIO_SDA_B	B27
	A28	GND	GND	B28
	A29	MCIO_CLK_B_Dp	PERSTNB_B_L3V3	B29
	A30	MCIO_CLK_B_Dn	PB_CBL_DET	B30
	A31	GND	GND	B31
	A32	PERp6	PETp6	B32
	A33	PERn6	PETn6	B33
	A34	GND	GND	B34
	A35	PERp7	PETp7	B35
	A36	PERn7	PETn7	B36
	A37	GND	GND	B37

# HARDWARE INSTALLATION

---

## 2.3 Installation

Use the instructions below to install a ARC-1389-32I switch adapter.

### Step 1. Unpack

Unpack and remove the switch adapter from the package. Inspect it carefully, if anything is missing or damaged, contact your local dealer.

### Electrostatic Discharge

Static electricity can cause serious damage to the electronic components on this switch adapter. To avoid damage caused by electrostatic discharge, observe the following precautions:

- Do not remove the switch adapter from its antistatic packaging until you are ready to install it into a computer case.
- Handle the switch adapter by its edges or by the metal mounting brackets at its each end.
- Before you handle the switch adapter in any way, touch a grounded, anti-static surface, such as an unpainted portion of the system chassis, for a few seconds to discharge any built-up static electricity.

### Step 2. Power PC/Server Off

Turn off computer and remove the AC power cord. Remove the system's cover. For the instructions, please see the computer system documentation.

### Step 3. Install the Switch Adapter

To install the switch adapter, remove the mounting screw and existing bracket from the rear panel behind the selected PCIe 5.0 x16 slot for better performance. Align the gold-fingered edge on the card with the selected PCIe slot. Press down gently but firmly to ensure that the card is properly seated in the slot, as shown in Figure 2-4. Then, screw the bracket into the computer chassis.

# HARDWARE INSTALLATION

---

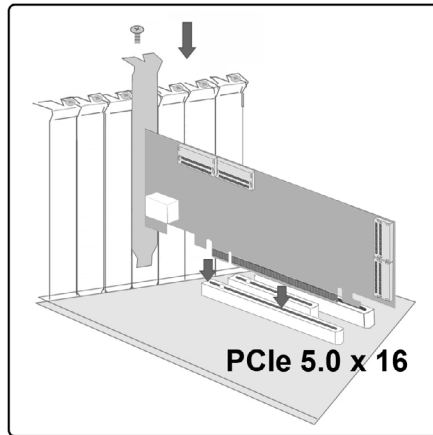

Figure 2-3, Insert into a PCIe Slot

## Step 4. Mount the NVMe Drives

You can connect the NVMe drives to the adapter through direct cable and backplane solutions.

(1). In the direct connection:

The NVMe drives are directly connected to NVMe switch adapter PHY port with proper cables. The NVMe switch adapter can support up to 32 PHY ports. Remove the front bezel from the computer chassis and install the cages or NVMe drives in the computer chassis. Loading drives to the drive tray if cages are installed. Be sure that the power is connected to either the cage backplane or the individual drives.

(2) In the backplane solution:

The NVMe drives are directly connected to system backplane or through a PCIe switch on the backplane board. The number of NVMe drives is limited to the number of slots available on the backplane. .

# HARDWARE INSTALLATION

## Step 5. Install Storage Connection Cable

The adapter has four x8 MCIO connectors. Each x8 connector provides two sets of SFF-9402 standard sidebands. It supports both the industry standard SFF-TA-1005 Specification for Universal Backplane Management (UBM) and maintains Virtual Pin Port (VPP) backplane management for legacy implementations. Choose the proper cable for the given backplane type and connectors. Connect the MCIO connector of the adapter to the backplane or NVMe SSD via the proper cable.

For backplane connector supporting, please refer to the system backplane manual and choose the proper cable from backplane storage cables for installation.

The following diagrams show how to cable a NVMe switch adapter to the SFF-8612 connector backplane or 8 bays M.2 drive cage.

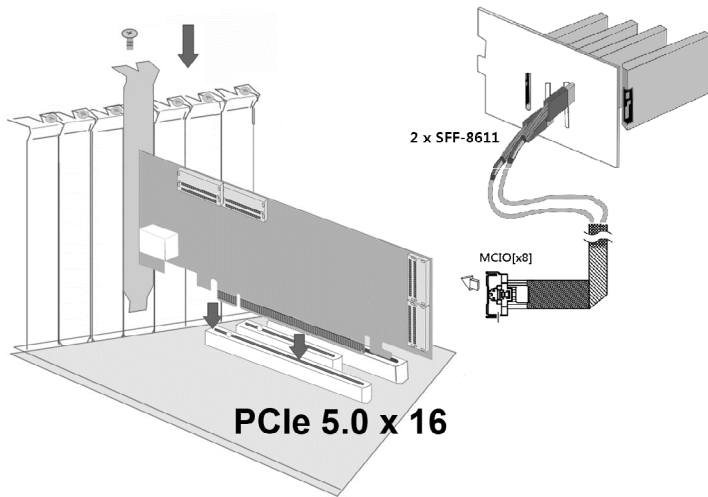

Figure 2-4, Connecting to NVMe Backplane

# HARDWARE INSTALLATION

---

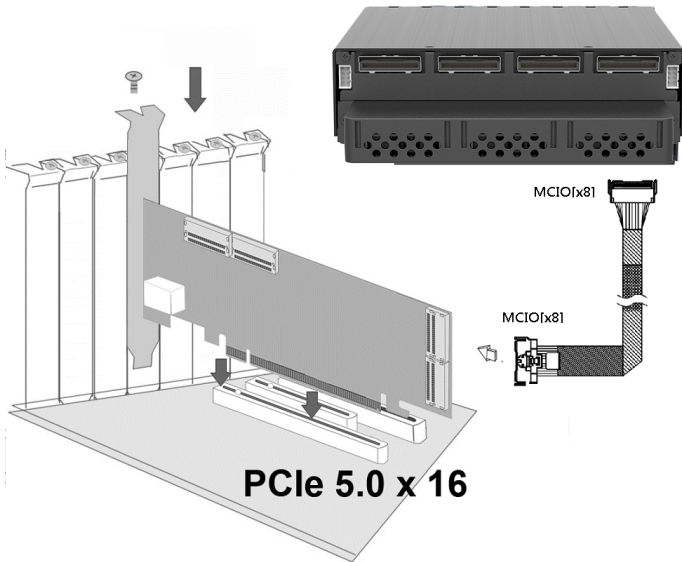

Figure 2-5, Connecting to NVMe Cadge

## Step 5. Power up the System

Thoroughly check the installation, reinstall the computer cover, and reconnect the power cord cables. Turn on the power switch at the rear of the computer (if equipped) and then press the power button at the front of the host computer.

## Step 6. Install the Adapter Driver

ARC-1389-32I NVMe switch adapter uses OS NVMe host (native) driver, no driver installation needed. All major operating systems natively support native NVMe driver. User does not need to install device drivers, or software management suite. All attached NVMe SSDs on the ARC-1389-32I will be automatically recognized by the operating system. If you don't monitor information from the adapter, belows step 8, step 9 and Step 10 can be ignored.

## Step 7. Manage Switch Adapter (optional)

The adapter status can be managed via the McBIOS switch setup

# HARDWARE INSTALLATION

---

utility and web-based switch storage manager. Refer to Chapter 3 of the user manual, McBIOS Switch Setup Utility, for the detail.

## Step 8. Install ArchHTTP Proxy Server (optional)

The switch adapter firmware has embedded the web-browser switch storage manager. ArchHTTP proxy server will launch the web-browser switch storage manager. It provides the management and monitor NVMe switch adapter status. Refer to the Chapter 4 ArchHTTP Proxy Server Installation and Chapter 5 Switch Storage Manager of the user manual, for the detail.

## Step 9. LAN Port Connection (Optional)

The ARC-1389-32I base switch adapter supports Ethernet port management and monitoring. The ARC-1389-32I base switch adapter has embedded the TCP/IP & web browser-based manager in the firmware. User can manage the adapter via standard web browsers directly connected to the RJ45 Ethernet port. Connect 10/100Mbit Ethernet port of the adapter to a Ethernet port or Ethernet switch. Refer to next section, Web Browser-based Configuration, for the detail.

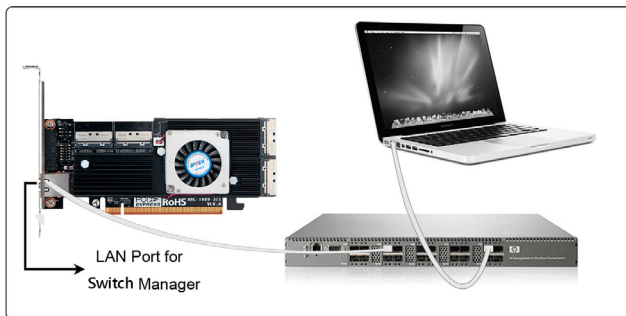

## 2.4 Serial Interface Bus

The serial interface connector can add optional accessories to add RAID adapter more functions. You can connect this interface to Areca LCD module for information, status indication, or menus or adapter LED indicator for status message. This interface can also cascade to another Areca serial bus accessories for the additional status display.

# HARDWARE INSTALLATION

The following picture and table are the serial bus signal name description for LCD & fault/activity LED.

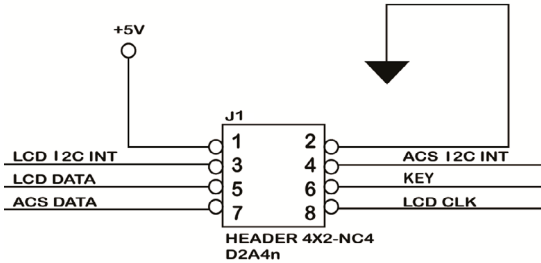

Pin	Description	Pin	Description
1	Power (+5V)	2	GND
3	LCD Module Interrupt	4	Protect Key
5	LCD Module Serial Data	6	Fault/Activity Clock
7	Fault/Activity Serial Data	8	LCD Module Clock

Table 2-3, Areca Serial Bus Pin Definition

ARC-1389-32I switch adapter supports one optional LCD front panel and keypad function to simply view adapter information without any creation function. The LCD status panel also informs user of the disk array’s current operating status at a glance. The LCD configuration is described in a separate manual: RAID Card\_ LCD manual. The LCD housed in a 5¼-inch half-height or 3.5 inch canister.

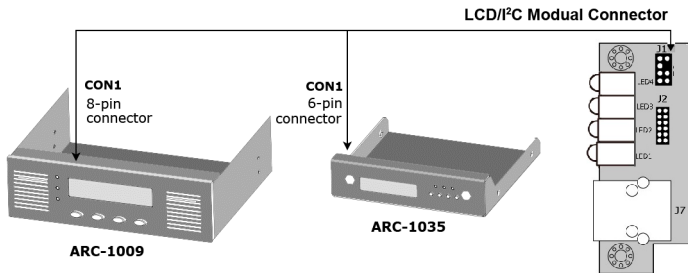

# HARDWARE INSTALLATION

## 2.5 Summary of the installation

The flow chart below describes the installation procedures for NVMe switch adapters.

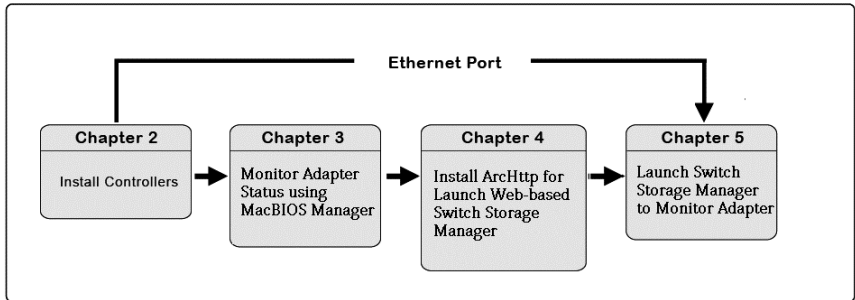

These procedures monitor the NVMe adapter through the McBIOS/switch setup utility, Ethernet port and installation of switch adapter software. The table below shows the software components that monitor the switch adapters.

Configuration Utility	Operating System Supported
McBIOS Switch Setup Utility	OS-Independent
Switch Storage Manager (Via on-board lan port)	OS-Independent
Switch Storage Manager (Via ArchHTTP proxy server)	Windows, Linux, and FreeBSD
ArchHTTP Proxy Server	Windows, Linux, and FreeBSD
CLI Utility	Windows, Linux, and FreeBSD
SAP Monitor (Scan multiple Switch units in the network)	Windows

### Switch Storage Manager

There are two ways to launch switch storage manager on the ARC-1389-32I switch adapter: in-band PCIe host bus interface or out-of-band built-in LAN interface. Before launching the firmware-embedded web browser, switch storage manager through the PCIe bus, you need first to install the ArchHTTP proxy server on your server system. If you need additional information about start-up of this function, see the Switch Storage Manager section in Chapter 5 of the user manual.

# HARDWARE INSTALLATION

---

## **ArcHTTP Proxy Server**

ArcHTTP has to be installed for GUI switch console (switch storage manager) to run. It is used to launch the web browser switch storage manager. It also runs as a service or daemon in the background that allows capturing of events for mail and SNMP traps notification. If you need additional information about installation and start-up of this function, see the ArcHTTP Proxy Server Installation section in Chapter 4 of the user manual.

## **CLI Utility**

CLI (Command Line Interface) lets you set up and manage switch adapter through a command line interface. CLI performs many tasks at the command line. You can download CLI manual from Areca website <https://www.areca.com.tw>.

## **Single Admin Portal (ArcSAP) Monitor**

This utility can scan and manage multiple switch and RAID units in the local and remote systems and provide an effective mechanism to configure and monitor your switch and RAID units. For additional information, see the utility manual (ArcSAP) from the web site <https://www.areca.com.tw>.

# BIOS CONFIGURATION

## 3. McBIOS Switch Setup Utility

The McBIOS switch setup utility is designed to be user-friendly. It is a menu-driven program, residing in the firmware, which allows you to scroll through various menus and sub-menus and select among the predetermined management options. This section explains how to launch the McBIOS switch setup utility to monitor your switch adapters that the installed motherboard 'BIOS Mode' is UEFI.

**M/B BIOS mode:** UEFI and CSM (compatibility support module) option = disabled

- a). Add switch adapters "UEFI OS(Areca A....)" in the M/B boot option: You must enter the setup of motherboard BIOS and add UEFI OS to the boot option if your motherboard BIOS does not automatically add it.

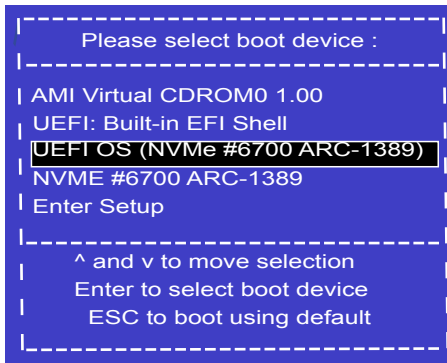

- b). Restart your motherboard to boot from UEFI OS. The motherboard vendors provide two methods for choosing a boot device: Enter boot menu by using hotkey or enter boot menu through BIOS configuration.

### **Note:**

UEFI OS is not loaded when setting the 'Secure Boot' option=enabled in M/B BIOS setup.

# BIOS CONFIGURATION

- c). When booted, the McBIOS switch setup utility window appears showing the main menu of the switch adapters that are installed in the system. If there have more than two switch adapters installed in the system, it will show a selection for user to choose one to configure the switch adapter. McBIOS setup utility operates upon a single switch adapter at a time. A selection dialog box listing the switch adapters that are installed in the system.

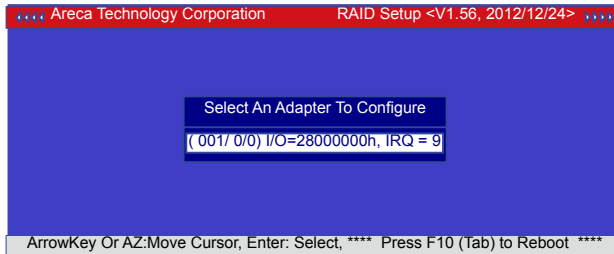

Use the **Up** and **Down** arrow keys to select the adapter you want to monitor. While the desired controller is highlighted, press the **Enter** key to enter the main menu of the McBIOS switch setup utility.

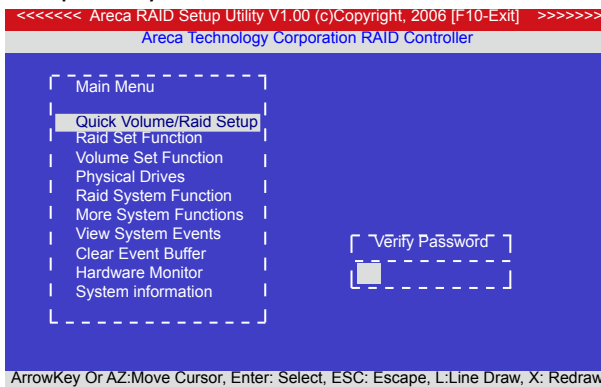

- d). Follow the on-screen prompts to complete the configuration. After using "F10" to exit, you can enter "shell>exit" or need to hard power cycle it.
- e). Enter the setup of motherboard BIOS to disable or adjust UEFI OS in the boot option priorities if it is the first priority of overall boot order. Otherwise the system will always boot into UEFI OS without using the hotkey.

# BIOS CONFIGURATION

---

**Note:**

The manufacture default password is set to **0000**; this password can be modified by selecting **Change Password** in the **Raid System Function** section.

## 3.1 Main Menu

Since ARC-1389-32I uses same ARC-1689-32I McBIOS setup utility interface, it will be not available any RAID function item on the McBIOS setup utility.

The main menu shows all functions that are available for executing actions, which is accomplished by clicking on the appropriate link. This password option allows user to set or clear the switch adapter's password protection feature. Once the password has been set, the user can only monitor and configure the switch adapter by providing the correct password. The password is used to protect the internal switch adapter from unauthorized entry. The adapter will prompt for the password only when entering the main menu from the initial screen. The switch adapter will automatically return to the initial screen when it does not receive any command in five minutes.

Option	Description
Quick Volume/Raid Setup	N/A
Raid Set Function	N/A
Volume Set Function	N/A
3.2 Physical Drives	Identify and view individual disk information
3.3 Raid System Function	Setup the switch system configuration
More System Function	N/A
3.4 Ethernet Config	On-board Lan port configuration
3.5 Alert By Mail Config	Mail notification setting sent by on-board lan port
3.6 View System Events	Record all system events in the buffer
3.7 Clear Event Buffer	Clear all information in the event buffer
3.8 Hardware Monitor	Show the hardware system environment status
3.9 System Information	View the adapter system information

# BIOS CONFIGURATION

## 3.2 Physical Drives

Choose this option from the main menu to select a physical disk and perform the operations listed above. Move the cursor bar to an item, then press **Enter** key to select the desired function.

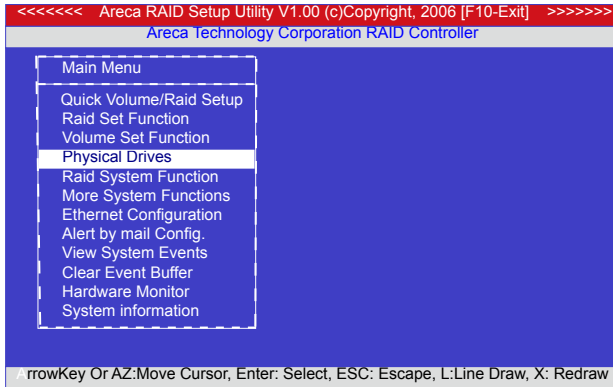

### 3.2.1 Identify Selected Drive

To prevent removing the wrong drive, the selected disk fault LED indicator will light for physically locating the selected disk when the "Identify Selected Device" is selected.

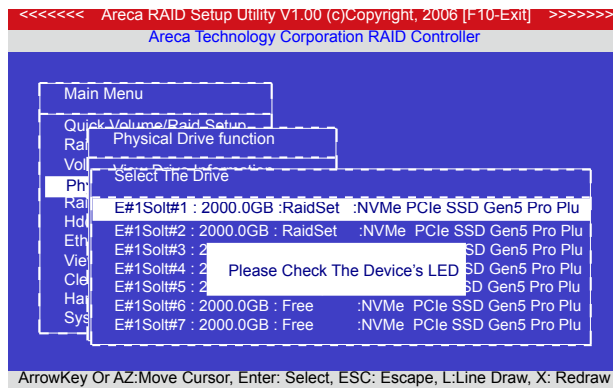

# BIOS CONFIGURATION

## 3.3 Raid System Function

To set the "Raid System Function", move the cursor bar to the main menu and select the "Raid System Function" item and then press **Enter** key. The "Raid System Function" menu will show multiple items. Move the cursor bar to an item, and then press **Enter** key to select the desired function.

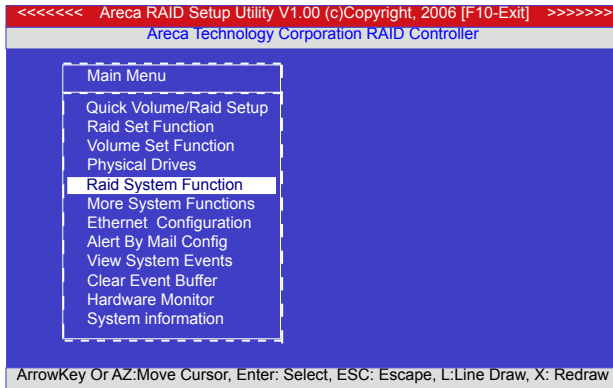

### 3.3.1 Mute The Alert Beeper

The "Mute The Alert Beeper" function item is used to control the NVMe Switch adapter beeper. Select **Yes** and press the **Enter** key in the dialog box to turn the beeper off temporarily. The beeper will still activate on the next event.

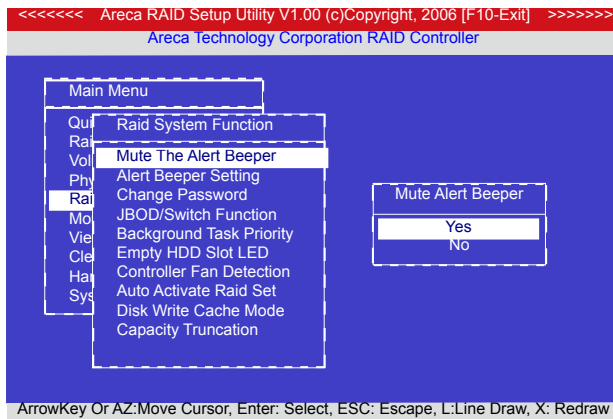

# BIOS CONFIGURATION

## 3.3.2 Alert Beeper Setting

The "Alert Beeper Setting" function item is used to "Disabled" or "Enabled" the NVMe Switch adapter alarm tone generator. Select "Disabled" and press the **Enter** key in the dialog box to turn the beeper off.

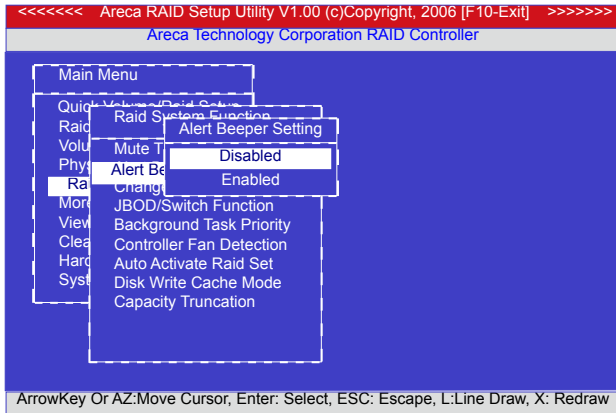

## 3.3.3 Change Password

**The manufacture default password is set to 0000.** The password option allows user to set or clear the password protection feature. Once the password has been set, the user can monitor and configure the adapter only by providing the correct password. This feature is used to protect the internal Switch system from unauthorized access. The adapter will check the password only when entering the main menu from the initial screen. The system will automatically go back to the initial screen if it does not receive any command in 5 minutes. To set or change the password, move the cursor to "Raid System Function" screen, press the "Change Password" item. The "Enter New Password" screen will appear. Do not use spaces when you enter the password, If spaces are used, it will lock out the user. To disable the password, only press **Enter** key in both the "Enter New Password" and "Re-Enter New Password" column. The existing password will be cleared. No password checking will occur when entering the main menu.

# BIOS CONFIGURATION

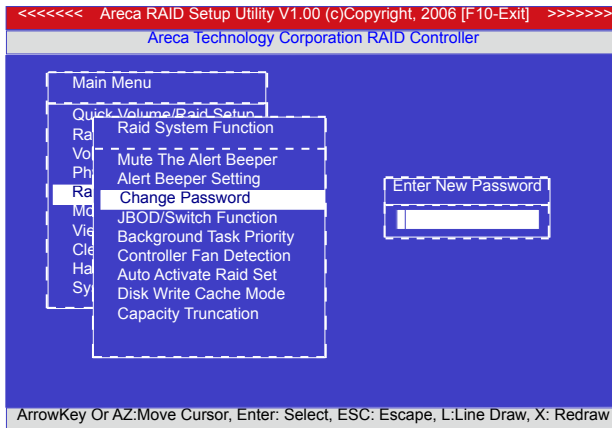

## 3.3.4 Controller Fan Detection

The ARC-1389-32I incorporate one big passive heatsink attaching two active cooling fans that allows the hot devices such as PCIe switch and M.2 NVMe module to keep cool. In addition, newer systems already have enough air flow blowing over the adapter. The "Controller Fan Detection" function is available in the firmware for detecting the cooling fan function on the heatsink which uses the active cooling fan. When using the passive heatsink on the adapter, disable the "Controller Fan Detection" function through this McBIOS switch setup utility setting. The following screen shot shows how to change the McBIOS switch setup utility setting to disable the warning beeper function.

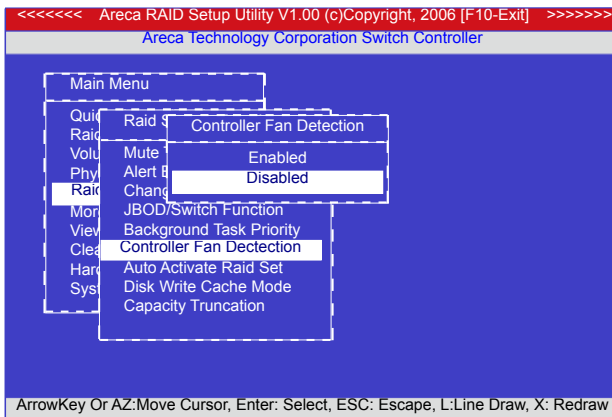

# BIOS CONFIGURATION

## 3.4 Ethernet Configuration

Use this feature to set the adapter Ethernet port configuration. It is not necessary to create reserved disk space on any hard disk for the Ethernet port and HTTP service to function; these functions are built into the adapter firmware. move the cursor bar to the main menu "Ethernet Configuration Function" item and then press the **Enter** key. The "Ethernet Configuration" menu appears on the screen. Move the cursor bar to an item, and then press **Enter** key to select the desired function.

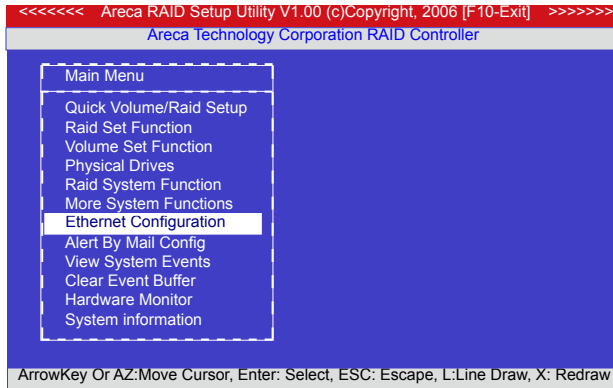

### 3.4.1 DHCP Function

DHCP allows network administrators centrally manage and automate the assignment of IP addresses on a computer network. When using the TCP/IP protocol, it is necessary for a computer to have a unique IP address in order to communicate to other computer systems. Without DHCP, the IP address must be entered manually at each computer system. DHCP lets a network administrator supervise and distribute IP addresses from a central point. The purpose of DHCP is to provide the automatic (dynamic) allocation of IP client configurations for a specific time period (called a lease period) and to minimize the work necessary to administer a large IP network. To manually configure the IP address of the adapter, move the cursor bar to DHCP Function item, then press **Enter** key to show the DHCP setting. Select the "Disabled" or "Enabled" option to enable or disable the DHCP function. If DHCP is disabled, it will be necessary to manually enter a static IP address that does not conflict with other devices on the network.

# BIOS CONFIGURATION

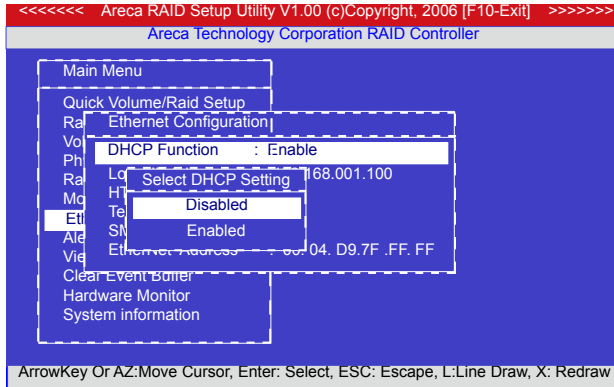

## 3.4.2 Local IP address

If you intend to set up your client computers manually (no DHCP), make sure that the assigned IP address is in the same range as the default router address and that it is unique to your private network. However, it is highly recommend to use DHCP if that option is available on your network. An IP address allocation scheme will reduce the time it takes to set-up client computers and eliminate the possibilities of administrative errors and duplicate addresses.

To manually configure the IP address of the adapter, move the cursor bar to Local IP address item, then press the **Enter** key to show the default address setting in the switch adapter. You can then reassign the static IP address of the adapter.

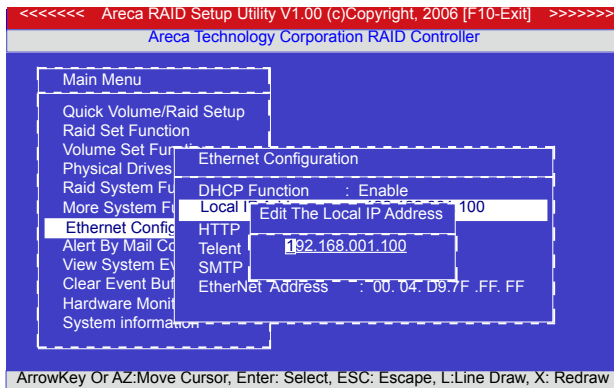

# BIOS CONFIGURATION

## 3.4.3 HTTP Port Number

To manually configure the "HTTP Port Number" of the adapter, move the cursor bar to "HTTP Port Number" item, then press the **Enter** key to show the default address setting in the switch adapter. Then You can reassign the default "HTTP Port Number" of the adapter.

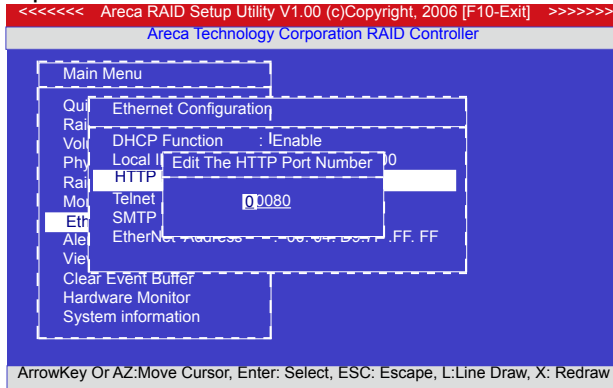

## 3.4.4 Telnet Port Number

To manually configure the "Telnet Port Number" of the adapter, move the cursor bar to "Telnet Port Number" item, then press the **Enter** key to show the default address setting in the adapter. You can then reassign the default "Telnet Port Number" of the adapter.

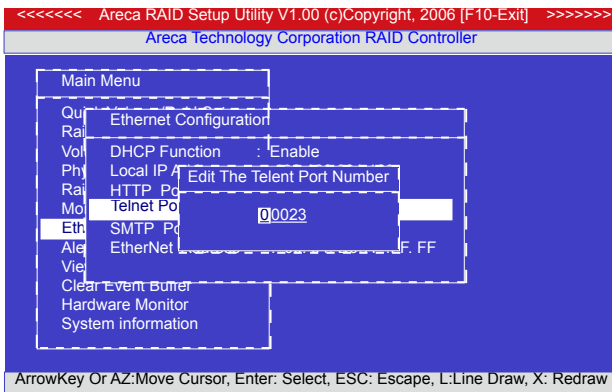

# BIOS CONFIGURATION

## 3.4.5 SMTP Port Number

To manually configure the “SMTP Port Number” of the adapter, move the cursor bar to the main menu “Ethernet Configuration” function item and then press **Enter** key. The “Ethernet Configuration” menu appears on the screen. Move the cursor bar to “SMTP Port Number” item, then press **Enter** key to show the default address setting in the switch adapter. You can then reassign the default “SMTP Port Number” of the adapter.

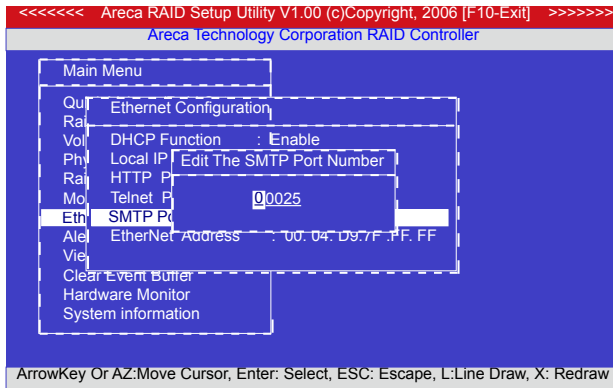

## 3.4.6 Ethernet Address

Each Ethernet port has its unique Mac address, which is also factory assigned. Usually, Ethernet address is used to uniquely identify a port in the Ethernet network.

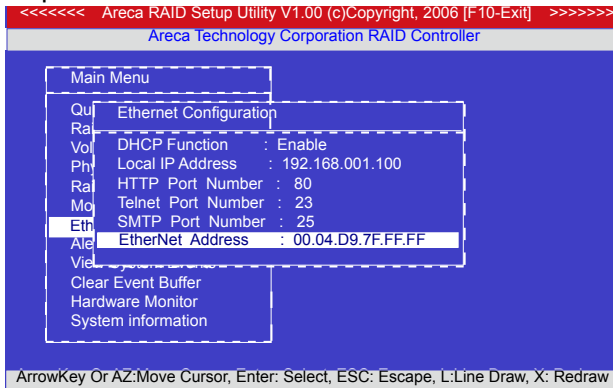

# BIOS CONFIGURATION

## 3.5 Alert By Mail Config

To configure the switch adapter e-mail function, move the cursor bar to the main menu and click on the "Alert By Mail Config" link. The "Alert By Mail Config" menu will show all items. Move the cursor bar to the "Alert By Mail Config" item, then select the desired function.

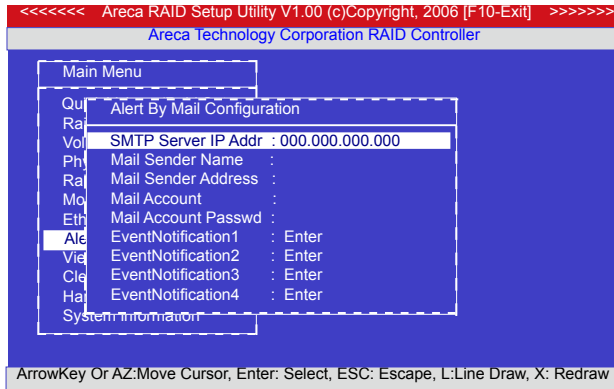

**SMTP Server IP Addr:**

Enter IP address or domain name of the SMTP server to configure your mail program correctly. Ex: 192.168.0.2.

**Mail Sender Name:**

This is the sender name that the e-mail alerts will appear to be coming from. Ex: RaidController\_1.

**Mail Sender Address:** This is the mail address that the e-mail alerts will appear to be coming from, but don't type IP to replace domain name. Ex: RaidController\_1@areca.com.tw.

**Mail Account:** Enter the valid account if your SMTP mail server requires authentication.

**Mail Account Password:**

Enter the valid password if your SMTP mail server requires authentication.

# BIOS CONFIGURATION

## EventNotification# : Event Notification Configurations

This step involves setting up of notification rules. Notification rules instruct "Alert By Mail" on the notifications that should be sent when certain types of alerts are detected.

MailTo Name:

Enter the alert receiver name that will be shown in the outgoing mail.

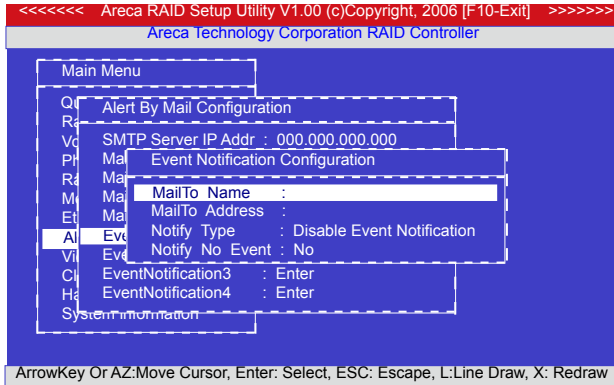

MailTo Address:

Enter the receiver's e-mail address. This is the address you want the e-mail alerts sent to. Ex: admin@areca.com.tw.

Notify Type:

According to your requirement, set the corresponding event level.

"Disable Event Notification" - No event notification will be sent.

"Urgent Error Notification" - Send only urgent events.

"Serious Error Notification" - Send urgent and serious events.

"Warning Error Notification" - Send urgent, serious and warning events.

"Information Notification" - Send all events.

Notification No Event:

Notify user if no event occurs within 24 hours.

# BIOS CONFIGURATION

## 3.6 View System Events

To view the NVMe switch adapter's system events information, move the cursor bar to the main menu and select the "View System Events" link, then press the **Enter** key. The NVMe switch adapter's events screen appear.

Choose this option to view the system events information: Timer, Device, Event type, Elapsed Time, and Errors. The switch adapter does not have a build-in real time clock. The time information is the relative time from the NVMe Switch adapter powered on.

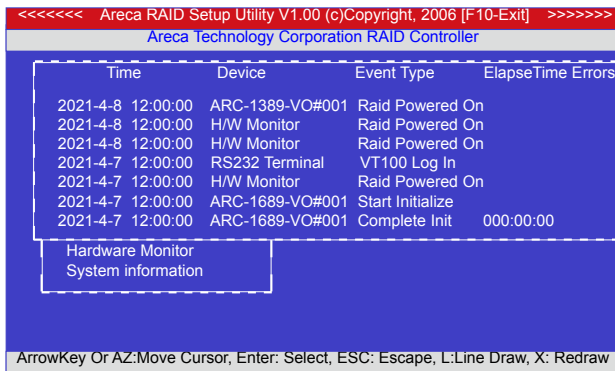

## 3.7 Clear Events Buffer

Use this feature to clear the entire events buffer.

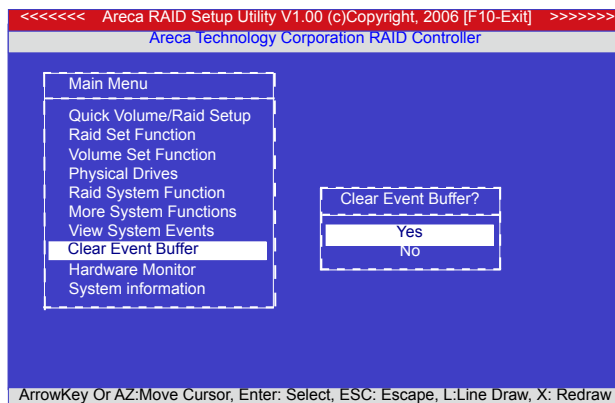

# BIOS CONFIGURATION

## 3.8 Hardware Monitor

To view the Switch adapter's hardware monitor information, move the cursor bar to the main menu and click on the "Hardware Monitor" link. The "Controller H/W Monitor" screen appears. The "Controller H/W Monitor" provides the PCIe switch chip temperature, adapter temperature and voltage of the NVMe switch adapter.

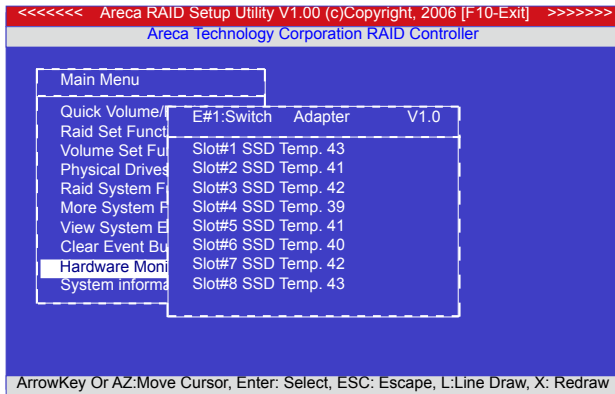

## 3.9 System Information

Choose this option to display adapter name, firmware version, BOOT ROM version, serial number, main processor, CPU instruction cache and data cache size, serial number, and controller name. To check the system information, move the cursor bar to "System Information" item, then press **Enter** key. All relevant adapter information will be displayed.

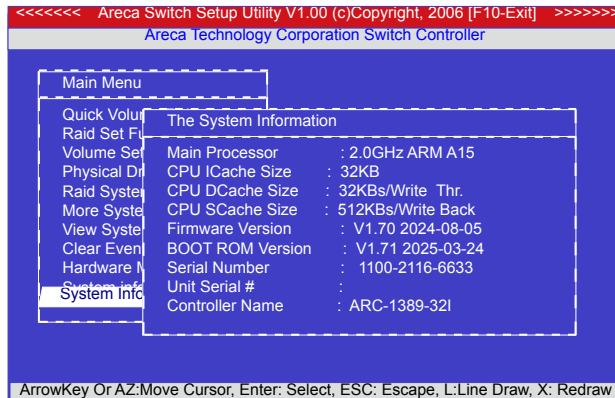

# ARCHTTP PROXY SERVER INSTALLATION

---

## 4. ArchHTTP Proxy Server Installation

### Overview

The NVMe disk drives connected to the NVMe switch adapter can be monitored through the built-in configuration that resides in the adapter's firmware. It provides to monitor the adapter, eliminating the need for additional hardware or software.

In addition, a software utility to monitor the NVMe switch adapter is provided on the areca website. This software utility can monitor the NVMe switch adapter. The software utility and switch storage manager can configure and monitor the NVMe switch adapter via ArchHTTP proxy server interface. The following table outlines their functions:

Configuration Utility	Operating System Supported
McBIOS Switch Setup Utility	OS-Independent
Switch Storage Manager (Via ArchHTTP proxy server)	Windows, Linux, and FreeBSD
SAP Monitor (Single Admin Portal to scan for multiple Switch units in the network, Via ArchHTTP proxy server)	Windows

The HTTP management software (ArchHTTP) runs as a service or daemon, and have it automatically start the proxy for all adapters found. This way the adapter can be managed remotely without having to sign in the server. The HTTP management software (ArchHTTP) also has integrated the email notification and SNMP extension agent. The email notification can be configured in local or remote standard web browser.

### 4.1 For Windows

This section describes how to install the switch software to your operating system. The software installation includes ArchHTTP and CLI utility.

In this scenario, you are installing the switch software in an existing Windows system. You can use the installer to install ArchHTTP and CLI at once or "Custom" to install special components. Follow the steps below to install the utility for Windows.

# ARCHTTP PROXY SERVER INSTALLATION

---

1. Download the install\_mraid installer from the website at "<https://www.areca.com.tw/support/downloads.htm>", the file name begins with "install\_mraid" followed by the version control.
2. Double-click on the zipped file that comes from the website to unzip it. Double-click on the "setup.exe" file for installing MSwitch.
3. The screen shows Preparing to Install.

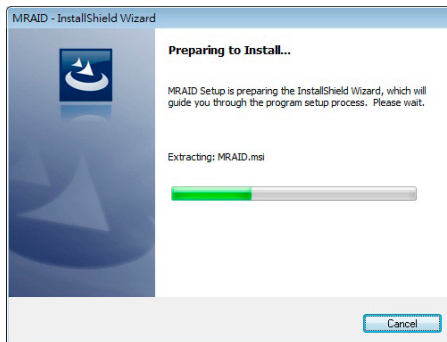

4. The Mraid Installer (or InstallShield Wizard) opens, preparing to install and click on the "**Next**" button to continue.



# ARCHTTP PROXY SERVER INSTALLATION

- When the License Agreement screen appears, read and agree to the license information; then let the InstallShield Wizard guide you through the installation process.

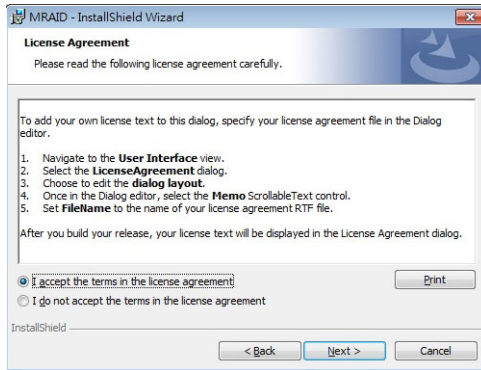

- On the Setup Type screen, use the settings to specify these things: and click on the "Next" button to continue.

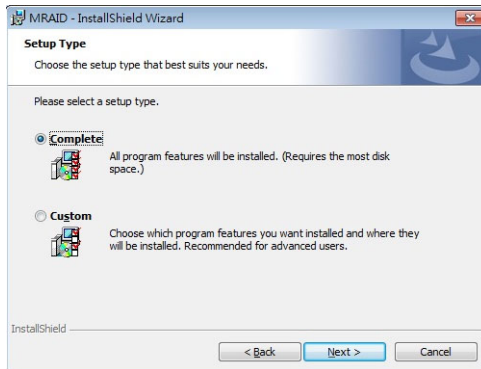

- "Complete" to install ArchHTTP and CLI utility at once, check the first box.
  - "Custom" to install special components and change the program directory. When this "Custom" check box is checked, go to the Custom Setup screen.
- On the Custom Setup screen, click on an icon to install special components and click on the "Next" button to continue.

# ARCHTTP PROXY SERVER INSTALLATION

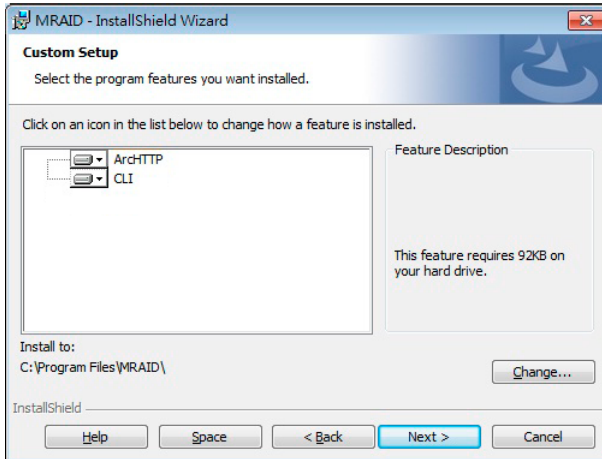

- **ArchHTTP** has to be installed for GUI switch console (switch storage manager) to run. It also runs as a service or daemon in the background that allows capturing of events for mail and SNMP traps notification. Refer to the section 4.4 ArchHTTP Configuration on ARC-1389-32I user manual, for details about the mail and SNMP traps configuration.
  - **CLI (Command Line Interface)** provides the functionality available in switch storage manager through a Command Line Interface. You can set up and manage switch storage inline. CLI performs many tasks at the command line. You can download CLI manual from Areca website.
7. When you reach the installation page, click on the “**Install**” button to continue.

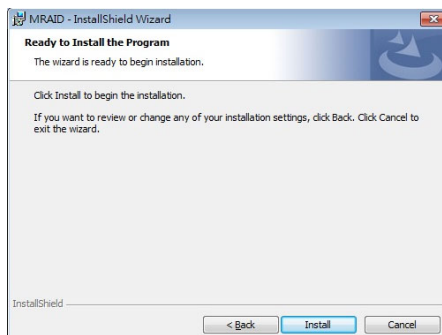

# ARCHTTP PROXY SERVER INSTALLATION

---

8. A program bar appears that measures the progress of the driver installation.

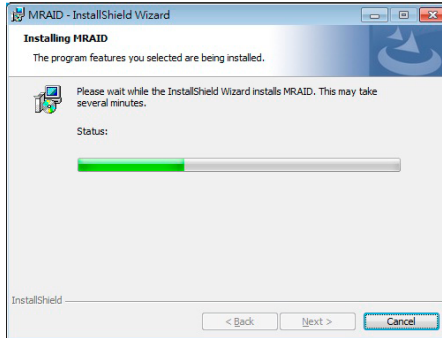

When this screen completes, you have completed the switch installation. If you have no ARC-1389-32I yet installed a "Switch Installer Information" message displays.

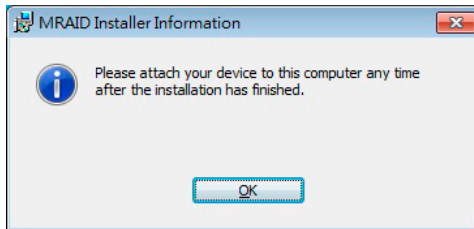

9. After installation is complete, click on the "Finish" button to exit the InstallShield Wizard.

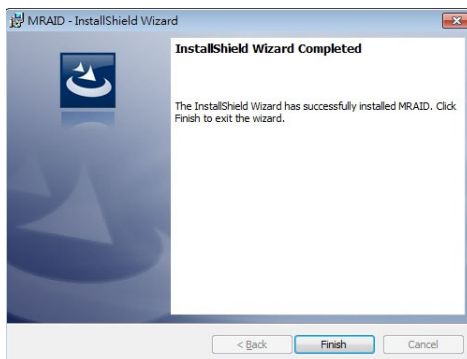

# ARCHTTP PROXY SERVER INSTALLATION

10. Once ArchHTTP and CLI have been installed, the ArchHTTP background task automatically starts each time when you start your computer. There is one Switch icon showing on your "Programs" folder. This icon is for you to start up the Switch storage manager (by ArchHTTP) and CLI utility.



The "ArchHTTP Taskbar" icon shows on the button of system tray by default. Double click "ArchHTTP Taskbar" to launch the ArchHTTP Configuration screen. It automatically scans the local-host switch adapters on the system and creates an total Controller List icon located in the left column screen. The child element belonged each Switch adapter appears on the right column screen. Locate "ARC-1389-32I" and launch the switch storage manager.

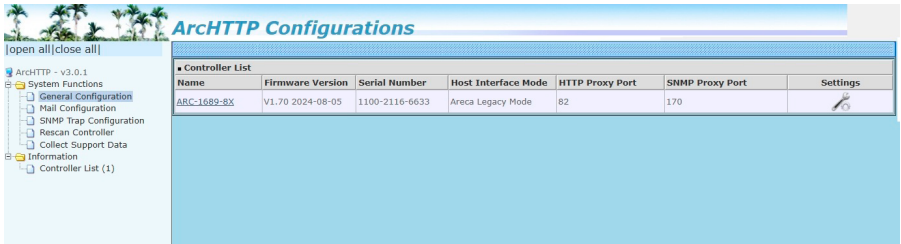

1. See the next chapter detailing the Switch Storage Manager to monitor your switch adapter.
2. If you need to configure the "System Function" of ArchHTTP, please refer to section 4.4 ArchHTTP Configuration.

# ARCHTTP PROXY SERVER INSTALLATION

---

## 4.2 For Linux

You should have administrative level permissions to install NVMe switch software. This procedure assumes that the NVMe switch hardware and Linux are installed and operational in your system.

The following installation procedure explains how to install the NVMe switch software for Linux. The ArchHTTP proxy server for the NVMe switch adapter card can download from the **<https://www.areca.com.tw>**. The firmware embedded switch storage manager can configure and monitor the NVMe switch adapter via ArchHTTP proxy server.

1. Login as root. Copy the ArchHTTP file to a local directory. Download from the [www.areca.com.tw](http://www.areca.com.tw) or from the email attachment.
2. You must have administrative level permissions to install and run Switch adapter ArchHTTP proxy server software. This procedure assumes that the NVMe switch hardware and driver are installed and operational in your system.

The following details are the installation procedure of the tri-mode Switch adapter for Linux ArchHTTP proxy server software.

- (a). Run the ArchHTTP proxy server by using the following command:  
Usage: `./archttp32 (TCP_PORT)` or `./archttp64 (TCP_PORT)`.  
It depends on your OS version.  
Parameters: TCP\_PORT value= 1~65535 (If TCP\_PORT assigned, ArchHTTP will start from this port. Otherwise, it will use the setting in the `archttpsrv.conf` or default 81). This is the port address assigning for the ArchHTTP configuration (Cfg Assistant). Such as: `archttp64 1553`
- (b). ArchHTTP server console started, adapter card detected then ArchHTTP proxy server screen appears.

# ARCHTTP PROXY SERVER INSTALLATION

---

Copyright (c) 2004-2024 Areca, Inc. All Rights Reserved.  
Areca HTTP proxy server, Version: v3.0.0, Arclib: 390, Date:  
Oct23 2024

Starting HTTP Proxy Server...Please wait(MAX = 5 minutes)  
Controller(s) list

-----  
Cfg Assistant : Listen to port[81].  
Controller[1](NVME) : Listen to port[82].  
Binding IP: [0.0.0.0]  
Note: IP[0.0.0.0] stands for any ip bound to this host.  
-----

#####  
Press CTRL-C to exit program!!  
#####

- (c). If you need the "Cfg Assistant", please refer to section 4.4 ArchTTP Configuration.
- (d). Launch your switch storage manager by entering `http://[Computer IP Address]:[Port Number]` in the web browser. For detailing about switch storage manager to monitor your switch adapter is discussed in Chapter 5.

# ARCHTTP PROXY SERVER INSTALLATION

---

## 4.3 For FreeBSD

You must have administrative level permissions to install NVMe Switch software. This procedure assumes that the NVMe Switch hardware and FreeBSD are installed and operational in your system.

The following installation procedure explains how to install the NVMe switch software for FreeBSD. The ArchHTTP proxy server for the NVMe Switch adapter card can download from the **<https://www.areca.com.tw>**. The firmware embedded switch storage manager can configure and monitor the NVMe switch adapter via ArchHTTP proxy server.

1. Login as root. Copy the ArchHTTP file to a local directory. Download from the [www.areca.com.tw](http://www.areca.com.tw) or from the email attachment.
2. This procedure assumes that the NVMe switch hardware and driver are installed and operational in your system. The following details are the installation procedure of the NVMe switch adapter ArchHTTP proxy server software.
  - (a). Run the ArchHTTP by using the following command:  
Usage: `./archttp32 (TCP_PORT)` or `./archttp64 (TCP_PORT)`.  
It depends on your OS version.  
Parameters: TCP\_PORT value= 1~65535 (If TCP\_PORT assigned, ArchHTTP will start from this port. Otherwise, it will use the setting in the `archttpsrv.conf` or default 81). This is the port address assigning for the ArchHTTP configuration (Cfg Assistant). Such as: `archttp64 1553`
  - (b). ArchHTTP server console started, adapter card detected then ArchHTTP proxy server screen appears.

# ARCHTTP PROXY SERVER INSTALLATION

---

Copyright (c) 2004-2024 Areca, Inc. All Rights Reserved.  
Areca HTTP proxy server, Version: v3.0.0, Arclib: 390, Date:  
Oct 23 2024

Starting HTTP Proxy Server...Please wait(MAX = 5 minutes)  
Controller(s) list

-----  
Cfg Assistant : Listen to port[81].  
ARCHTTP PROXY SERVER INSTALLATION  
Controller[1](NVME) : Listen to port[82].  
Binding IP: [0.0.0.0]  
Note: IP[0.0.0.0] stands for any ip bound to this host.  
-----

#####  
Press CTRL-C to exit program!!  
#####

- (c). If you need the "Cfg Assistant", please refer to section 4.4 ArchTTP Configuration.
- (d). Launch your switch storage manager by entering `http://[Compute IP Address]:[Port Number]` in the web browser. For detailing about switch storage manager to monitor your switch adapter is discussed in Chapter 5.

# ARCHTTP PROXY SERVER INSTALLATION

## 4.4 ArchHTTP Configuration

The ArchHTTP proxy server will automatically assign one additional port for setup its configuration. If you want to change the “archttpsrv.conf” setting up of ArchHTTP proxy server configuration, for example: General Configuration, Mail Configuration, and SNMP Configuration, please start Web Browser `http://localhost: Cfg Assistant`. Such as `http://localhost: 81`. The port number for the first adapter Switch storage manager is ArchHTTP proxy server configuration port number plus 1.

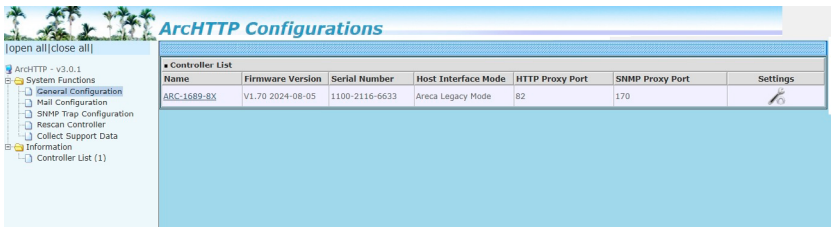

### ● **General Configuration:**

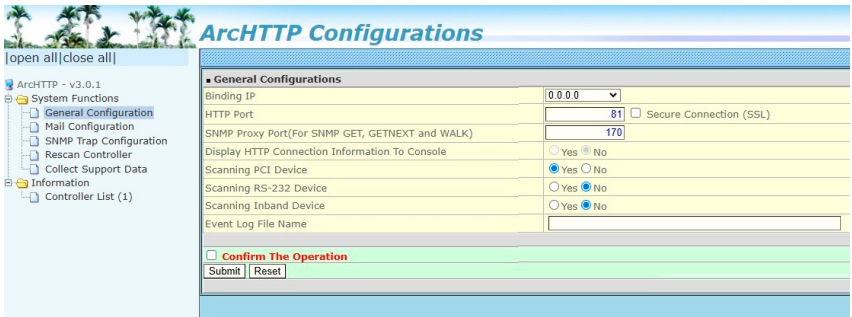

#### 1. **Binding Ip:**

Restrict ArchHTTP proxy server to bind only single interface (If more than one physical network in the server).

#### 2. **HTTP Port#:**

Value 1~65535. Click on the “check box” to enable the SSL.

#### 3. **SNMP Proxy Port (For SNMP GET, GET NEXT and WALK):**

The ArchHttp can send get requests to an SNMP agent to obtain data. After receiving a get request, the SNMP agent executes the corresponding instruction in the MIB and sends the result to the ArchHttp. It does not need a subagent.

# ARCHTTP PROXY SERVER INSTALLATION

- 4. Display HTTP Connection Information to Console:**  
Select "Yes" to show Http send bytes and receive bytes information in the console.
  - 5. Scan PCI Device:**  
Select "Yes" for ARC-1XXX series adapter.
  - 6. Scan RS-232 Device:**  
Select "No" for ARC-1XXX series adapter.
  - 7. Scan Inband Device:**  
Select "No" for ARC-1XXX series adapter.
  - 8. Event Log File Name:**  
Redefine the file name for "Collect Data" function.
- **Mail (Alert by Mail) Configuration:**

Many users require that email notifications be sent to the appropriate administrators when an alert is detected. To set up your mail servers, click on the "Mail Configuration" link. The "SMTP Server Configurations" allows you to define settings for your mail server. This setup screen is shown as below:

SMTP Server Configuration	
SMTP Server IP Address	<input type="text"/>
SMTP Hostname	<input type="text" value="75"/> <input type="checkbox"/> Secure Connection (SSL)
Mail Address Configurations	
Sender Name	<input type="text"/>
Mail Address	<input type="text"/>
Account	<input type="text"/>
Password	<input type="text"/>
Event Notification Configurations	
Mail Address	<input type="text"/>
<input checked="" type="radio"/> Disable Event Notification	No Event Notification Will Be Sent
<input type="radio"/> Urgent Error Notification	Send Only Urgent Event
<input type="radio"/> Serious Error Notification	Send Urgent And Serious Event
<input type="radio"/> Warning Error Notification	Send Urgent, Serious And Warning Event
<input type="radio"/> Information Notification	Send All Event
<input type="checkbox"/> Notification For No Event	Notify User If No Event Occurs Within 24 Hours
MailTo Name1	<input type="text"/>
<input checked="" type="radio"/> Disable Event Notification	No Event Notification Will Be Sent
<input type="radio"/> Urgent Error Notification	Send Only Urgent Event
<input type="radio"/> Serious Error Notification	Send Urgent And Serious Event
<input type="radio"/> Warning error Notification	Send Urgent, Serious And Warning Event
<input type="radio"/> Information Notification	Send All Event
<input type="checkbox"/> Notification For No Event	Notify User If No Event Occurs Within 24 Hours
MailTo Name2	<input type="text"/>
<input checked="" type="radio"/> Disable Event Notification	No Event Notification Will Be Sent
<input type="radio"/> Urgent error Notification	Send Only Urgent Event
<input type="radio"/> Serious Error Notification	Send Urgent, Serious And Warning Event
<input type="radio"/> Warning Error Notification	Send Urgent, Serious And Warning Event
<input type="radio"/> Information Notification	Send All Event
<input type="checkbox"/> Notification For No Event	Notify User If No Event Occurs Within 24 Hours
MailTo Name3	<input type="text"/>
<input checked="" type="radio"/> Disable Event Notification	No Event Notification Will Be Sent
<input type="radio"/> Urgent Error Notification	Send Only Urgent Event
<input type="radio"/> Serious Error Notification	Send Urgent And Serious Event
<input type="radio"/> Warning Error Notification	Send Urgent, Serious And Warning Event
<input type="radio"/> Information Notification	Send All Event
<input type="checkbox"/> Notification For No Event	Notify User If No Event Occurs Within 24 Hours

The following article describes a best practice methodology for setting this up in the "SMTP Server Configurations".

## 1. SMTP Server Configuration:

SMTP Server IP Address: Enter IP address or domain name of the SMTP server to configure your mail program correctly.  
Ex: 192.168.0.2. or smtp.gmail.com

# ARCHTTP PROXY SERVER INSTALLATION

---

## 2. Mail Address Configurations:

Sender Name: This is the sender name that the e-mail alerts will appear to be coming from.

Ex: RaidController\_1.

Mail address: This is the mail address that the e-mail alerts will appear to be coming from, but don't type IP to replace domain name.

Ex: RaidController\_1@areca.com.tw.

Account: Enter the valid account if your SMTP mail server requires authentication.

Password: Enter the valid password if your SMTP mail server requires authentication.

## 3. Event Notification Configurations:

This step involves setting up of notification rules. Notification rules instruct ArchHTTP on the notifications that should be sent when certain types of alerts are detected.

MailTo Name: Enter the alert receiver name that will be shown in the outgoing mail.

Mail Address: Enter the receiver's e-mail address. This is the address you want the e-mail alerts sent to.

Ex: admin@areca.com.tw.

According to your requirement, set the corresponding event level:

Disable Event Notification: No event notification will be sent.

Urgent Error Notification: Send only urgent events.

Serious Error Notification: Send urgent and serious events.

Warning Error Notification: Send urgent, serious and warning events.

Information Notification: Send all events.

Notification For No Event: Notify user if no event occurs within 24 hours.

## ● SNMP Traps Configuration:

This section discusses how to enable the SNMP traps on your Switch adapter, and how to control the sending of SNMP traps from the ArchHTTP. To send the SNMP traps to client SNMP manager such as Net-SNMP manager using the IP address assigned to the operating system, you can simply use the SNMP function on the ArchHTTP. The ArchHTTP only provides to send the trap without needing to install the SNMP extension agent on the host.

# ARCHTTP PROXY SERVER INSTALLATION

ArchHTTP - v3.0.1

- System Functions
  - General Configuration
  - Mail Configuration
  - SNMP Trap Configuration
  - Rescan Controller
  - Collect Support Data
- Information
  - Controller List (1)

### SNMP Trap Configurations

SNMP Trap IP Address #1	0	0	0	0	Port#	162
SNMP Trap IP Address #2	0	0	0	0	Port#	162
SNMP Trap IP Address #3	0	0	0	0	Port#	162
SNMP Trap IP Address #4	0	0	0	0	Port#	162
SNMP Trap IP Address #5	0	0	0	0	Port#	162

### SNMP System Configurations

Community: public

### SNMP Trap Notification Configurations

Disable Event Notification: No Event Notification Will Be Sent

Urgent Error Notification: Send Only Urgent Event

Serious Error Notification: Send Urgent And Serious Event

Warning Error Notification: Send Urgent, Serious And Warning Event

Information Notification: Send All Event

Confirm The Operation

Submit | Reset

The following article describes a best practice methodology for setting this up in the "SNMP Traps Configurations".

## 1. SNMP Trap Configurations

Enter the SNMP trap IP address.

## 2. SNMP System Configurations

Community name acts as a password to screen accesses to the SNMP agent of a particular network device. Type the community names of the SNMP agent in this field. Most network devices use "public" as default of their community names. This value is case-sensitive.

## 3. SNMP Trap Notification Configurations

Event Notification Table refers to Appendix C. Before the client side SNMP manager application accepts the Switch storage traps, it is necessary to integrate the MIB into the management application's database of events and status indicator codes. Ensure the compilation process successfully integrates the contents of the areca\_sas.mib file into the traps database. The MIBs file can download from <https://www.areca.com.tw>. Each Switch adapter needs to have its own MIBs file. Areca provide 4 adapters MIBs file for users. User can request it if more adapters install on one system.

### Note:

After you confirm and submit configurations, you can use "Generate Test Event" feature to make sure these settings are correct.

# ARCHTTP PROXY SERVER INSTALLATION

- **Rescan Device Configuration:**

The ArchHTTP scans the switch adapters on the system and creates an individual switch adapter icon located on left column of the "ArchHTTP Configurations" screen. If any switch adapter is missed at system start-up, then you can use the "Rescan Device" function to rescan the targets to allow a missed switch storage to be added.

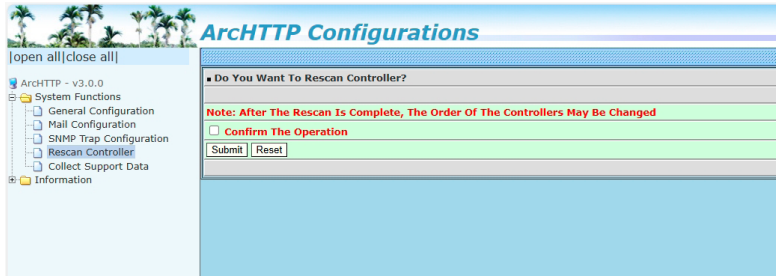

- **Collect Support Data:**

The "Collect Support Data" option on the ArchHTTP is used to download all adapter's information (system information, disk information and hardware information) to program directory (file name:ctrlxx-xxxxx.log). It will be automatically started when URGENT or SERIOUS event has occurred.

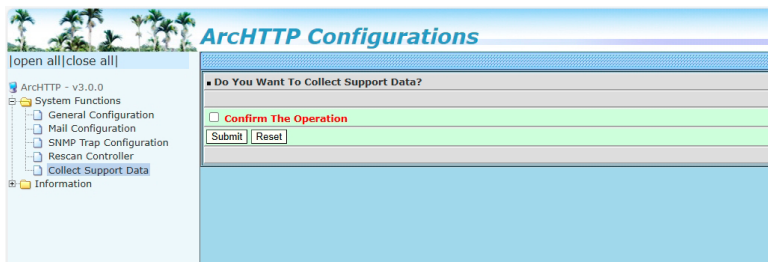

# WEB BROWSER-BASED CONFIGURATION

---

## 5. Web Browser-based Configuration

The switch storage manager is firmware-based utility, which is accessible via the web browser installed on your operating system. The web browser-based switch storage manager is a HTML-based application, which utilizes the browser (Edge, Chrome and Mozilla etc.) installed on your monitor station.

It can be accessed through the in-band PCIe bus or out-of-band LAN port. ArchHTTP is used to launch the in-band web browser-based switch storage manager. The firmware-embedded web browser-based switch storage manager allows local or remote to access it from any standard internet browser via a LAN or WAN. The firmware contains SMTP manager monitors all system events and user can select either single or multiple user notifications to be sent via LAN with "Plain English" e-mails. The firmware-embedded SNMP agent allows remote to monitor events via LAN with no SNMP agent required.

### 5.1 Start-up Switch Storage Manager

With switch storage manager, you can:

- Locally manage a system containing a supported switch adapter that has Windows or macOS, ArchHTTP and a supported browser.
- **Start-up from Windows Local Administration**

Once ArchHTTP and CLI have been installed, the ArchHTTP - background task automatically starts each time when you start your computer.



or one "**ArchHTTP Taskbar**" icon showing on Windows system tray. This icon is for you to start up the ArchHTTP (launch the switch storage manager). When you click on the ArchHTTP64 from "**ArchHTTP Taskbar**" from system tray, it shows all switch adapters available on the host system and create an individual switch adapter icon located on left column of the "ArchHTTP Configurations" screen. This switch adapter icon is for user to launch the selected switch adapter web browser switch storage manager.

# WEB BROWSER-BASED CONFIGURATION

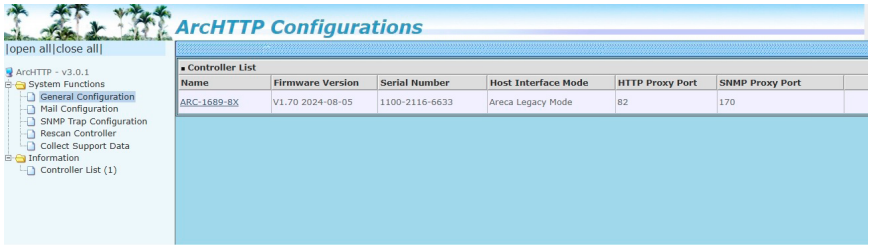

The “Enter Network Password” dialog screen appears, type the User Name and Password. The switch adapter default User Name is “admin” and the Password is “0000”. After entering the user name and password, press **Enter** key to access the switch storage manager.

- **Start-up Switch Storage Manager from Linux/ FreeBSD Local Administration**

To configure the internal NVMe switch adapter. From switch storage manager, you need to know its IP address. You can find the IP address assigned by the ArcHTTP proxy server installation: Binding IP:[X.X.X.X] and adapter listen port. See chapter 4.2/4.3 for ArcHTTP proxy server installation.

1. You can click on the individual adapter icon located on left column of the “ArcHTTP Configurations” screen or Launch your switch storage manager by entering `http://[Computer IP Address]:[Port Number]` in the web browser.
2. When connection is established, the "System Login" screen appears. The NVMe switch adapter default user name is “admin” and the password is “0000”.

- **Start-up from Ethernet Port (Out-of-Band)**

The ARC-1389-32I switch adapter also offers an alternative out-of-band method for switch storage manager. User can access the built-in configuration without running the ArcHttp proxy server on the host system. The web browser-based switch storage manager is a HTML-based application, which utilizes the browser installed on your remote system. To ensure proper communications between the NVMe switch adapter and switch storage manager, please connect the NVMe switch adapter LAN port to any LAN switch port.

# WEB BROWSER-BASED CONFIGURATION

The switch adapter has embedded the TCP/IP & web browser-based switch storage manager in the firmware. User can remote manage the NVMe switch adapter without adding any user specific software (platform independent) via standard web browsers directly connected to the 10/100Mbit RJ45 LAN port.

To configure NVMe switch adapter on a remote machine, you need to know its IP address. The IP address is default shown on the LCD initial start-up screen and McBIOS "System Information" option. Launch your switch storage manager by entering `http://[IP Address]` in the web browser.

## 5.2 Switch Storage Manager

The following login screen is displayed in the browser. This screen displays the initial start-up configuration.

The screenshot shows the web browser-based configuration interface for the Areca Technology Corporation. The interface includes a navigation menu on the left and a main content area with two tables.

**RAID Set Hierarchy**

RAID Set	Devices	Volume Set(Ch/Id/Lun)	Volume State	Capacity

**Enclosure#1 : RAID Adapter V1.0**

Device	Usage	Capacity	Link Control	Link Status	Errors	Model
Slot#1	Host DirectIO	2000-4GB	4xG5	4xG5	00	NVMe PCIe SSD Gen5 Pro Plus
Slot#2	Host DirectIO	2000-4GB	4xG5	4xG5	00	NVMe PCIe SSD Gen5 Pro Plus
Slot#3	Host DirectIO	2000-4GB	4xG5	4xG5	00	NVMe PCIe SSD Gen5 Pro Plus
Slot#4	Host DirectIO	2000-4GB	4xG5	4xG5	00	NVMe PCIe SSD Gen5 Pro Plus
Slot#5	Host DirectIO	2000-4GB	4xG5	4xG5	00	NVMe PCIe SSD Gen5 Pro Plus
Slot#6	Host DirectIO	2000-4GB	4xG5	4xG5	00	NVMe PCIe SSD Gen5 Pro Plus
Slot#7	Host DirectIO	2000-4GB	4xG5	4xG5	00	NVMe PCIe SSD Gen5 Pro Plus
Slot#8	Host DirectIO	2000-4GB	4xG5	4xG5	00	NVMe PCIe SSD Gen5 Pro Plus

- To display drive information, move the mouse cursor to the desired physical drive number, then click on it. The drive information will be displayed. Use this feature to view the RAID switch adapter current physical NVMe device information. The firmware can monitor and check the current attached device status. It includes slot control capabilities, slot link status, transaction error count reports and device information. Web GUI device information (included S.M.A.R.T) via Archttp utility inquiry from Host OS. ARC-1389-32I adapter only supports Host DirectIO mode. In this mode, NVMe devices connected to ARC-1389-32I are managed by the Host OS. Install Archttp Utility to inquiry Device information (included S.M.A.R.T) from OS and pass to ARC-1389-32I firmware web GUI. Link and Model are physical layer information. Firmware can directly inquiry from PEX89048 switch chip. But Capacity (command layer) need to via Archttp utility from OS.

# WEB BROWSER-BASED CONFIGURATION

## 5.3 Main Menu

The main menu shows all available functions, accessible by clicking on the appropriate link. Since ARC-1389-32I uses same ARC-1689-32I GUI interface, it will be not available any RAID function item on the web-based browser manager.

Individual Category	Description
Quick Function	N/A
Raid Set Functions	N/A
Volume Set Functions	N/A
Security Functions	N/A
5.4 Physical Drives	Provides the function to identify disk drives (blinking fault LED).
5.6 System Controls	Setting the switch adapter configuration.
5.7 Information	Viewing the adapter information. The Raid Set Hierarchy can be viewed through the "Raid Set Hierarchy" item.

## 5.4 Physical Drive

Choose this option to select a physical disk from the main menu and then perform the operations listed below.

### 5.4.1 Identify Drive

To prevent removing the wrong drive, the selected disk fault LED indicator will light for physically locating the selected disk when the "Identify Selected Device" is selected.

**Areca Technology Corporation**

[open all] [close all]

- Raid System Console
- Quick Function
- RAID Set Functions
- Volume Set Functions
- Security Functions
- Physical Drives
  - Create Pass-Through Disk
  - Modify Pass-Through Disk
  - Delete Pass-Through Disk
  - Host DirectIO Config
  - Clone Disk
  - Abort Cloning
  - Set Disk To Be Failed
  - Activate Failed Disk
  - Identify Enclosure
  - Identify Drive**
- System Controls
- Information

**Select The Device For Identification**

■ Enclosure#1 : RAID Adapter V1.0

<input checked="" type="radio"/>	Slot#1	1000.2GB	NVMe Samsung SSD 9100 PRO 1TB
<input type="radio"/>	Slot#2	1000.2GB	NVMe Samsung SSD 9100 PRO 1TB
<input type="radio"/>	Slot#3	1000.2GB	NVMe Sabrent SB-RKT5-1TB
<input type="radio"/>	Slot#4	1000.2GB	NVMe Sabrent SB-RKT5-1TB
<input type="radio"/>	Slot#5	1000.2GB	NVMe CT1000T700SSD3
<input type="radio"/>	Slot#6	1000.2GB	NVMe CT1000T700SSD3
<input type="radio"/>	Slot#7	1000.2GB	NVMe Corsair MP700 ELITE
<input type="radio"/>	Slot#8	1000.2GB	NVMe Corsair MP700 ELITE

Submit | Reset

# WEB BROWSER-BASED CONFIGURATION

## 5.5 System Controls

### 5.5.1 System Config

To set the switch system function, move the cursor to the main menu and click on the "System Controls" link. The "Raid System Function" menu will show all items, and then select the desired function.

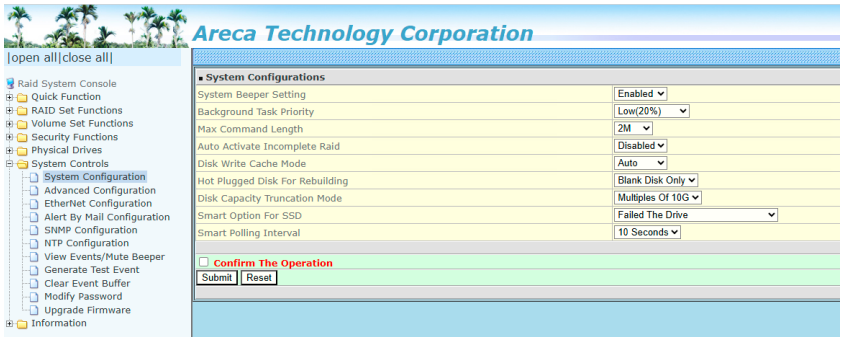

#### • System Beeper Setting

The "System Beeper Setting" function is used to "Disabled" or "Enabled" the NVMe switch adapter alarm tone generator.

### 5.5.2 Advanced Configuration

To set the Switch system function, move the cursor to the main menu and click on the "Advanced Configuration" link. The "Advanced Configuration" menu will show all items, then select the desired function

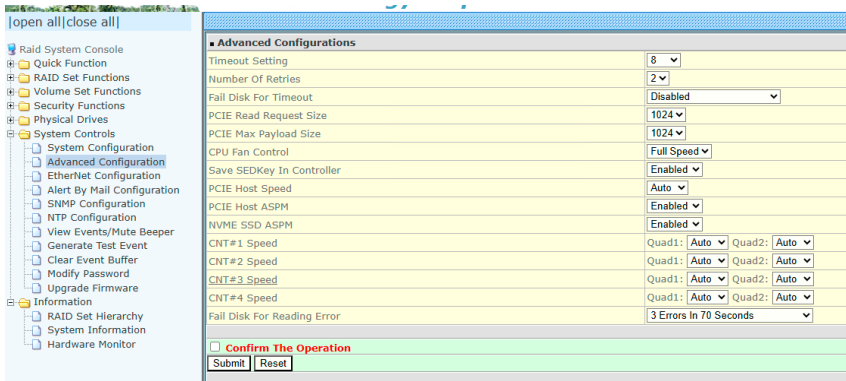

# WEB BROWSER-BASED CONFIGURATION

---

- **PCIE Read Request Size**

The maximum read request size (MRRS) in PCIe defines the largest chunk of data that a device can request in a single read transaction. It's a configurable parameter, typically set to values like 128B, 256B, 512B, 1024B, 2048B, or 4096B. The MRRS, along with the Max Payload Size (MPS), helps optimize data transfer and prevent one device from monopolizing PCIe bandwidth.

- **PCIE Max Payload Size**

The PCIe Max Payload Size (MPS) determines the maximum amount of data that can be transmitted in a single PCIe Transaction Layer Packet (TLP). It's a configuration setting negotiated between the PCIe device and the host, and influences the efficiency of data transfer. Larger MPS values can lead to increased bandwidth utilization and potentially better performance, but also require more hardware resources for processing. It's a configurable parameter, typically set to values like 128B, 256B, 512B, 1024B, 2048B, or 4096B.

- **CPU Fan Control**

You can select "Full Speed" or "Auto" to control switch adapter Fan.

- **Full Speed** : CPU fan always run at full speed.

- **Auto** : RAID adapter automatically adjust fan speed based on the current temperature of switch adapter.

- **PCIE Host Speed**

Use the PCIe Host Speed option to PCI Express speed at which the server allows PCI Express devices to operate. The option can also used to address issues with problematic PCI Express devices. Setting this value to Maximum Supported configures the platform to run at the maximum speed supported by the platform or the PCIe device, whichever is lower. It's a configurable parameter, typically set to values like Auto, Gen2, Gen3, Gen4, or Gen5.

- **PCIE Host ASPM**

PCIe Host Active State Power Management (ASPM) is a power

# HARDWARE INSTALLATION

---

management mechanism implemented at the PCIe link layer. Its primary purpose is to automatically adjust the PCIe link to a low-power state without requiring direct involvement from the system software, thereby saving energy. When a PCIe link is idle or has low traffic, ASPM allows it to enter a lower power consumption state. It's a configurable parameter, typically set to values Enabled or Disabled.

- **NVMe SSD ASPM**

NVMe SSD Active State Power Management (ASPM) is a power management mechanism implemented at the NVMe link layer. Its primary purpose is to automatically adjust the NVMe link to a low-power state without requiring direct involvement from the system software, thereby saving energy. When a NVMe link is idle or has low traffic, ASPM allows it to enter a lower power consumption state. It's a configurable parameter, typically set to values Enabled or Disabled.

- **CNT#x Speed (NVMe Speed)**

Each MCIO [x8] CNT # includes two quads (Quad1 and Quad2). Use the CNT#x Speed option to NVMe speed at which the ARC-1389-32I allows NVMe device to operate. The option can also be used to address issues with problematic NVMe devices. Setting this value to Maximum Supported configures the platform to run at the maximum speed supported by the ARC-1389-32I or the NVMe device, whichever is lower. It's a configurable parameter, typically set to values like Auto, Gen2, Gen3, Gen4, or Gen5.

## 5.5.3 Ethernet Configuration

Use this feature to set the adapter Ethernet port configuration. A customer doesn't need to create a reserved space on the arrays before the Ethernet port and HTTP service are working. The firmware-embedded web browser-based switch manager can access it from any standard internet browser or from any host computer either directly connected or via a LAN or WAN with no software or patches required.

To configure the RAID adapter Ethernet port, move the cursor bar to the main menu and click on the "System Controls" link. The "System Controls" menu will show all items. Move the cursor bar

# HARDWARE INSTALLATION

to the “Ethernet Configuration” item, then select the desired function.

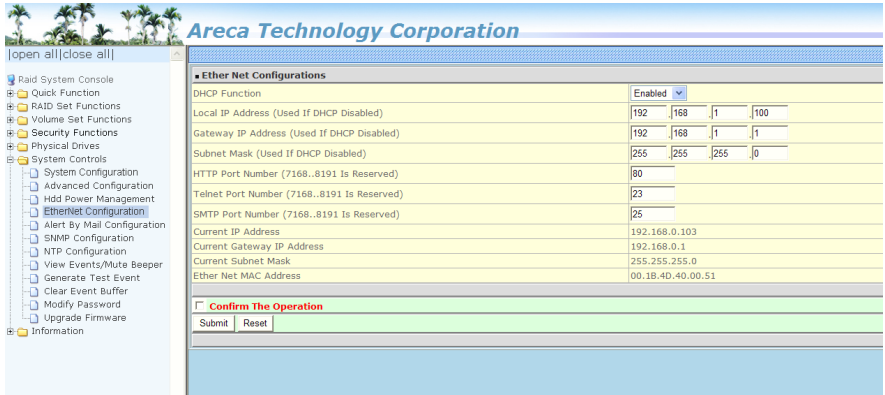

## ● DHCP Function

DHCP (Dynamic Host Configuration Protocol) is a protocol that lets network administrators manage centrally and automate the assignment of IP (Internet Protocol) configurations on a computer network. When using the internet’s set of protocols (TCP/IP), in order for a computer system to communicate to another computer system, it needs a unique IP address. Without DHCP, the IP address must be entered manually at each computer system. DHCP lets a network administrator supervise and distribute IP addresses from a central point. The purpose of DHCP is to provide the automatic (dynamic) allocation of IP client configurations for a specific time period (called a lease period) and to eliminate the work necessary to administer a large IP network. Select the “Disabled” or “Enabled” option to enable or disable the DHCP function. If DHCP is disabled, it will be necessary to manually enter a static IP address that does not conflict with other devices on the network.

## ● Local IP Address (Used If DHCP Disabled)

If you intend to set up your client computers manually (no DHCP), make sure that the assigned IP address is in the same range as the default router address and that it is unique to your private network. However, it is highly recommended to use DHCP if that option is available on your network. An IP address

# WEB BROWSER-BASED CONFIGURATION

---

allocation scheme will reduce the time it takes to set-up client computers and eliminate the possibilities of administrative errors and duplicate addresses. It shows the default address setting in the RAID controller. You can then reassign the static IP address of the controller.

- **Gateway IP Address (Used If DHCP Disabled)**

A gateway IP address is the address of a router on your local network that directs traffic to other networks, such as the internet. It acts as a “default gateway” for your devices, sending their requests to destinations outside your local network

- **Subnet Mask (Used If DHCP Disabled)**

The subnet mask defines the portion of the IP address that identifies the network, so selecting the correct subnet mask ensures that your device can communicate with other devices on the local network and the internet

- **HTTP Port Number**

This option manually configures the “HTTP Port Number” of the controller. It shows the default address setting in the switch adapter. Then You can reassign the default “HTTP Port Number” of the adapter.

**Note:**

If you configure the HTTP Port Number to 0, the HTTP console will be closed.

- **Telnet Port Number**

This option manually configures the “Telnet Port Number” of the controller. It shows the default address setting in the RAID controller. You can then reassign the default “Telnet Port Number” of the controller.

# WEB BROWSER-BASED CONFIGURATION

- **SMTP Port Number**

This option manually configures the “SMTP Port Number” of the controller. It shows the default address setting in the RAID controller. You can then reassign the default “SMTP Port Number” of the controller

## 5.5.4 Alert By Mail Configuration

To configure the NVMe switch adapter e-mail function, move the cursor bar to the main menu and click on the “System Controls” link. The “System Controls” menu will show all items. Move the cursor bar to the “Alert By Mail Configuration” item, then select the desired function. This function can only be set via web-based configuration.

The firmware contains a SMTP manager monitoring all system events. Single or multiple user notifications can be sent via “Plain English” e-mails with no software required.

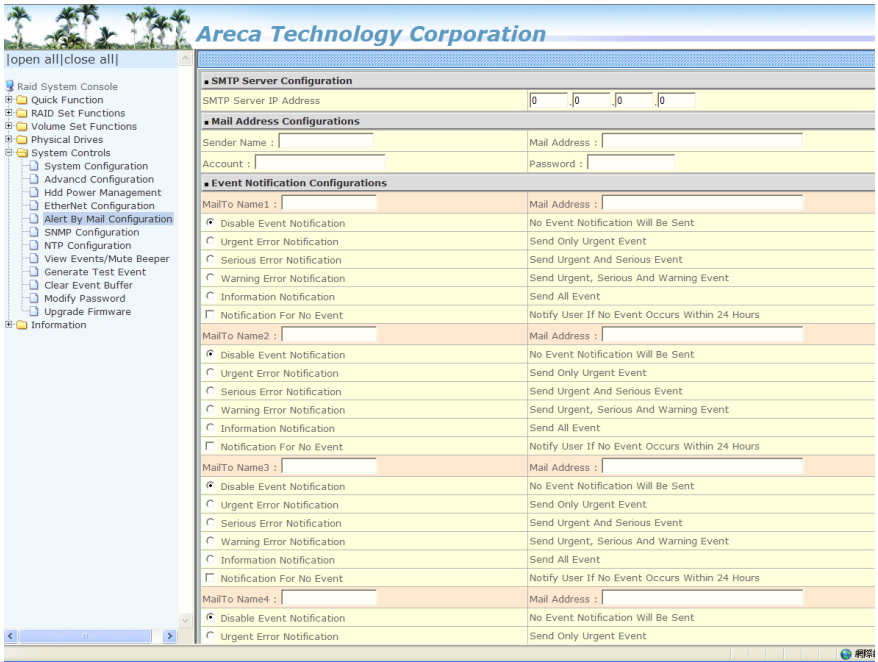

# WEB BROWSER-BASED CONFIGURATION

---

The following article describes a best practice methodology for setting this up in the "SMTP Server Configurations".

## **1. SMTP Server Configuration:**

SMTP Server IP Address: Enter IP address or domain name of the SMTP server to configure your mail program correctly.

Ex: 192.168.0.2. or smtp.gmail.com

## **2. Mail Address Configurations:**

Sender Name: This is the sender name that the e-mail alerts will appear to be coming from.

Ex: RaidController\_1.

Mail address: This is the mail address that the e-mail alerts will appear to be coming from, but don't type IP to replace domain name.

Ex: RaidController\_1@areca.com.tw.

Account: Enter the valid account if your SMTP mail server requires authentication.

Password: Enter the valid password if your SMTP mail server requires authentication.

## **3. Event Notification Configurations:**

This step involves setting up of notification rules. Notification rules instruct ArchHTTP on the notifications that should be sent when certain types of alerts are detected.

MailTo Name: Enter the alert receiver name that will be shown in the outgoing mail.

Mail Address: Enter the receiver's e-mail address. This is the address you want the e-mail alerts sent to.

Ex: admin@areca.com.tw.

According to your requirement, set the corresponding event level:

Disable Event Notification: No event notification will be sent.

Urgent Error Notification: Send only urgent events.

Serious Error Notification: Send urgent and serious events.

Warning Error Notification: Send urgent, serious and warning events.

Information Notification: Send all events.

Notification For No Event: Notify user if no event occurs within 24 hours.

# WEB BROWSER-BASED CONFIGURATION

## 5.5.5 SNMP Configuration

The following article describes a best practice methodology for setting this up in the 'SNMP Traps Configuration'.

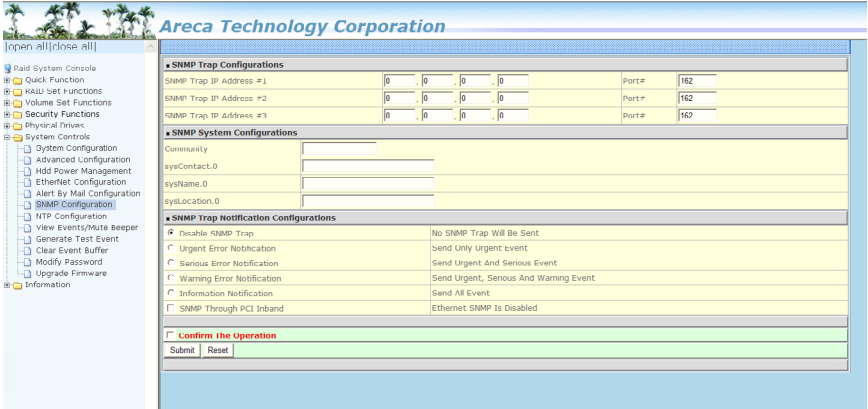

### 1. SNMP Trap Configurations

Enter the SNMP trap IP address.

### 2. SNMP System Configurations

Community name acts as a password to screen accesses to the SNMP agent of a particular network device. Type the community names of the SNMP agent in this field. Most network devices use "public" as default of their community names. This value is case-sensitive.

### 3. SNMP Trap Notification Configurations

Event Notification Table refers to Appendix C. Before the client side SNMP manager application accepts the switch storage traps, it is necessary to integrate the MIB into the management application's database of events and status indicator codes. Ensure the compilation process successfully integrates the contents of the areca\_sas.mib file into the traps database.

The MIBs file can download from <https://www.areca.com.tw>. Each switch adapter needs to have its own MIBs file. Areca provide 4 adapters MIBs file for users. User can request it if more adapters install on one system.

# WEB BROWSER-BASED CONFIGURATION

## 5.5.6 Time Zone Configuration

The Network Time Protocol (NTP) is used to synchronize the time of a computer client or server to another server or reference time source, such as a radio or satellite receiver or modem. It provides accuracies typically within a millisecond on LANs and up to a few tens of milliseconds on WANs relative to Coordinated Universal Time (UTC) via a Global Positioning Service (GPS) receiver, for example:

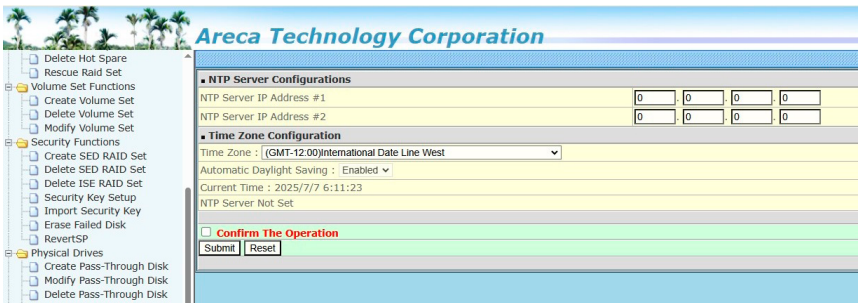

- **NTP Server Address**

The most important factor in providing accurate, reliable time is the selection of NTP servers to be used in the configuration file. Typical NTP configurations utilize multiple redundant servers and diverse network paths in order to achieve high accuracy and reliability. Our NTP configuration supports two existing public NTP synchronization subnets.

- **Time Zone**

Time Zone conveniently runs in the system tray and allows you to easily view the date and time in various locations around the world. You can also quickly and easily add your own personal locations to customize time zone the way you want.

- **Automatic Daylight Saving**

Automatic Daylight Saving will normally attempt to automatically adjust the system clock for daylight saving changes based on the computer time zone. This tweak allows you to disable the automatic adjustment.

**Note:**

NTP feature works through onboard Lan port. So you must make sure that you have connected onboard Lan port.

# WEB BROWSER-BASED CONFIGURATION

## 5.5.7 View Events/Mute Beeper

To view the NVMe switch adapter’s event information, click on the “View Event/Mute Beeper” link. The NVMe switch adapter “System events Information” screen appears. The mute beeper function automatically enable by clicking on “View Events/Mute Beeper”. Select this option to view the system events information: Time, Device, Event Type, Elapse Time and Errors. The switch adapter does not have a built-in real time clock. The time information is the relative time from the system time setting. The maximum event no. is 256 per adapter.

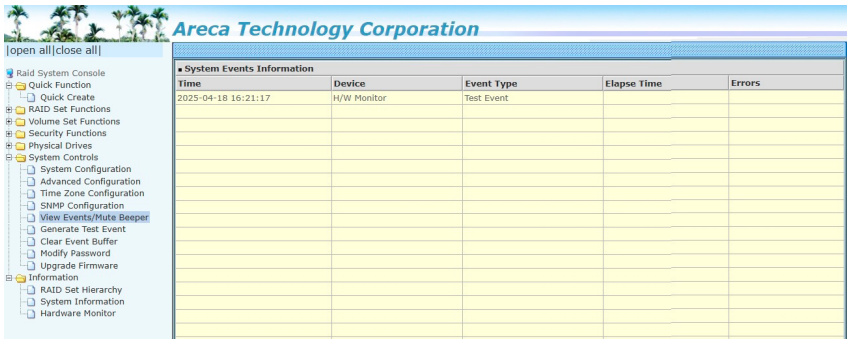

## 5.5.8 Generate Test Event

Use this feature to generate events for testing purposes.

## 5.5.9 Clear Events Buffer

Use this feature to clear the entire events buffer.

## 5.5.10 Modify Password

To set or change the NVMe switch adapter password, select “System Controls” from the menu and click on the “Modify Password” link. The “Modify System Password” screen appears. The password option allows user to set or clear the password protection feature. **The manufacture default password is set to 0000.**

# WEB BROWSER-BASED CONFIGURATION

Once the password has been set, the user can monitor and configure the adapter only by providing the correct password. This feature is used to protect the internal switch adapter from unauthorized access. The adapter will check the password only when entering the main menu from the initial screen. The system will automatically go back to the initial screen if it does not receive any command in 5 minutes. Do not use spaces when you enter the password, If spaces are used, it will lock out the user. To disable the password, leave the fields blank. Once the user confirms the operation and clicks on the "Submit" button, the existing password will be cleared. Then, no password checking will occur when entering the main menu from the starting screen.

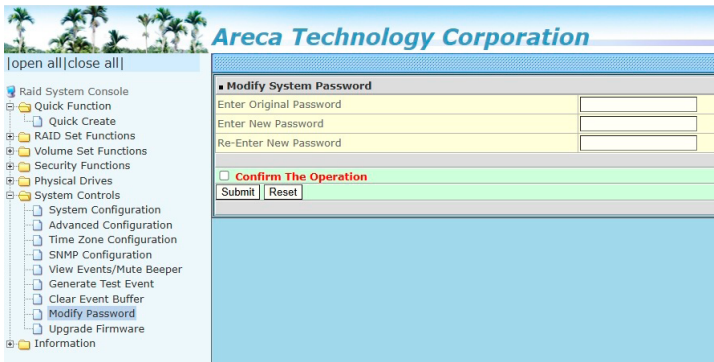

## 5.5.11 Update Firmware

Please refer to the appendix A "Upgrading Flash ROM Update Process".

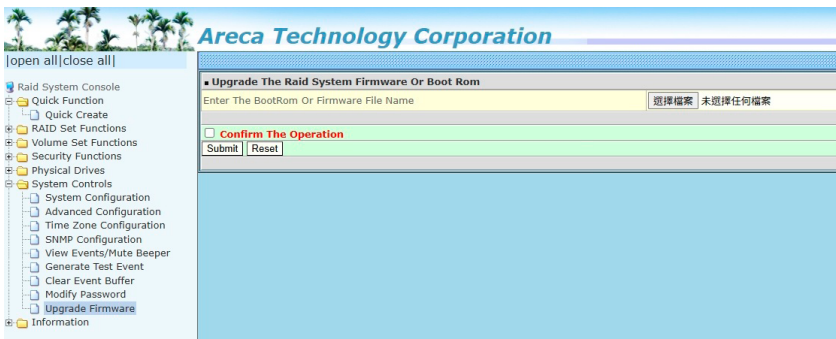

# WEB BROWSER-BASED CONFIGURATION

## 5.6 Information

### 5.6.1 Raid Set Hierarchy

Use this feature to view the NVMe switch adapter current physical disk information. The Usage and model are also shown in this screen.

The screenshot shows the RAID Set Hierarchy web interface. The left sidebar contains a navigation menu with the following items: RAID System Console, Quick Function, RAID Set Functions, Volume Set Functions, Security Functions, Physical Drives, System Controls, Information, RAID Set Hierarchy (selected), System Information, and Hardware Monitor. The main content area displays the RAID Set Hierarchy table, which is currently empty. Below it, the Enclosure#1 : RAID Adapter V1.0 table is shown, listing 8 slots with their respective usage, capacity, link control, link status, errors, and model.

■ RAID Set Hierarchy							
RAID Set	Devices	Volume Set(Ch/Id/Lun)	Volume State	Capacity			
■ Enclosure#1 : RAID Adapter V1.0							
Device	Usage	Capacity	Link Control	Link Status	Errors	Model	
Slot#1	Host DirectIO	2000.4GB	4xG5	4xG5	00	NVMe PCIe SSD Gen5 Pro Plus	
Slot#2	Host DirectIO	2000.4GB	4xG5	4xG5	00	NVMe PCIe SSD Gen5 Pro Plus	
Slot#3	Host DirectIO	2000.4GB	4xG5	4xG5	00	NVMe PCIe SSD Gen5 Pro Plus	
Slot#4	Host DirectIO	2000.4GB	4xG5	4xG5	00	NVMe PCIe SSD Gen5 Pro Plus	
Slot#5	Host DirectIO	2000.4GB	4xG5	4xG5	00	NVMe PCIe SSD Gen5 Pro Plus	
Slot#6	Host DirectIO	2000.4GB	4xG5	4xG5	00	NVMe PCIe SSD Gen5 Pro Plus	
Slot#7	Host DirectIO	2000.4GB	4xG5	4xG5	00	NVMe PCIe SSD Gen5 Pro Plus	
Slot#8	Host DirectIO	2000.4GB	4xG5	4xG5	00	NVMe PCIe SSD Gen5 Pro Plus	

#### ● Device & Slot Signal Integrity Information

The "Raid Set Hierarchy" menu will show all items, and then select the "Device" item. This area can view the RAID adapter current physical device information and slot signal integrity status. The firmware can monitor and check the current attached device status. It includes slot control capabilities, slot link status, transaction error count reports and device information. An error count refers to the number of bit errors detected by the physical layer transceivers within the PCIe switch. These errors can be correctable, where the system can recover without data loss or intervention, or uncorrectable, which negatively impacts the interface's function and a high rate can indicate underlying signal integrity issues that may impact performance (latency, bandwidth) or system failures.

### 5.6.2 System Information

To view the NVMe switch adapter's system information, move the mouse cursor to the main menu and click on the "System Information" link. The NVMe switch adapter "RAID Subsystem Information" screen appears. Use this feature to view the NVMe switch adapter's system information. The adapter name, adapter

# WEB BROWSER-BASED CONFIGURATION

firmware version, Boot ROM version, serial number, main processor, CPU instruction/data cache size, and PCI-E link status appear in this screen.

The screenshot shows the 'RAID Subsystem Information' screen. On the left is a navigation tree with 'Hardware Monitor' selected. The main content area displays a table of system information.

■ RAID Subsystem Information	
Controller Name	ARC-1389-32I
Firmware Version	V1.73 2025-11-14
BOOT ROM Version	V1.73 2025-11-14
Serial Number	1100-2116-6633
Unit Serial #	
Main Processor	2.0GHz Cortex-A15 RevA0
CPU ICache Size	32KBytes
CPU DCache Size	32KBytes/Write Back
CPU SCache Size	512KBytes/Write Back
PCI-E Link Status	4X/8G
PCI-E Payload Size	128

## 5.6.3 Hardware Monitor

Provides the PCIe switch temperature, adapter temperature and voltage of the NVMe switch adapter on this screen.

The screenshot shows the 'Hardware Monitor' screen. On the left is a navigation tree with 'Hardware Monitor' selected. The main content area displays a table of hardware monitoring data.

<input type="checkbox"/> Stop Auto Refresh	
■ Controller H/W Monitor	
Main Temperature	43 °C
Temperature#0	43 °C
Temperature#1	46 °C
Temperature#2	48 °C
Temperature#3	45 °C
Temperature#4	45 °C
0.8V	0.840 V
1.25V	1.232 V
1.8V	1.818 V
12V	11.951 V
Battery Status	Not Installed
■ Enclosure#1 : RAID Adapter V1.0	
Slot#1 SSD Temp.	40 °C
Slot#2 SSD Temp.	39 °C
Slot#3 SSD Temp.	33 °C
Slot#4 SSD Temp.	32 °C
Slot#5 SSD Temp.	33 °C
Slot#6 SSD Temp.	34 °C
Slot#7 SSD Temp.	39 °C
Slot#8 SSD Temp.	47 °C

# APPENDIX

---

## Appendix A

### Upgrading Flash ROM Update Process

#### A-1 Overview

Since the NVMe Switch adapter features flash ROM firmware, it is not necessary to change the hardware flash chip in order to upgrade the switch adapter firmware. The user can simply re-program the old firmware through the in-band PCIe bus, switch storage manager or nflash DOS utility. New releases of the firmware are available in the form of a DOS file on Areca website. The files available at the website for each model contain the following files in each version:

ARC1389UEFI.BIN:→ An EFI shell and home brewed small application

ARC1389BOOT.BIN :→ switch adapter hardware initialization

ARC1389FIRM.BIN :→ management kernel program

*Release\_note\_version-date.TXT* contains the history information of the software code change in the main directory. This file can download from <https://www.areca.com.tw/support/downloads.html> page. Read this file first to make sure you are upgrading to the proper binary file. Select the right file for the upgrade. Normally, user upgrades the ARC1389FIRM.BIN for management function. All these files in the firmware package are a part of the firmware. You should update all files in the package, no special update order needed. New firmware works after a system restart not instantant available, so you can update all files before restart the system. The adapter firmware is independent of the array, update firmware does not touch anything you stored in the array.

#### **Note:**

Please update all binary code (UEFI, BOOT, and FIRM) before you reboot system. Otherwise, a mixed firmware package may result the adapter hang.

# APPENDIX

## A-2 Upgrading Firmware Through Switch Storage Manager

Get the new version firmware for your NVMe switch adapter. For example, download the bin file from your OEM's web site onto the C: drive.

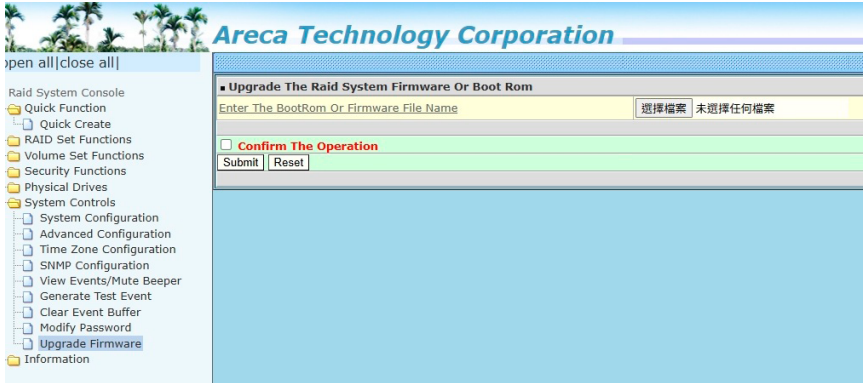

1. To upgrade the NVMe switch adapter firmware, move the mouse cursor to "Upgrade Firmware" link. The "Upgrade The Switch System Firmware or Boot Rom" screen appears.
2. Click on "Browse". Look in the location to which the Firmware upgrade software was downloaded. Select the file name and click on "Open".
3. Tick on "Confirm The Operation" and press the "Submit" button.
4. The web browser begins to download the firmware binary to the adapter and start to update the flash ROM.
5. After the firmware upgrade is complete, a bar indicator will show "Firmware Has Been Updated Successfully".
6. After the new firmware package completes downloading, find a chance to restart the adapter/computer for the new firmware to take effect.

The web browser-based switch storage manager can be accessed through the in-band PCIe bus. The in-band method uses the ArchHTTP proxy server to launch the switch storage manager.

# APPENDIX

---

## A-3 Upgrading Firmware Through nflash DOS Utility

Areca now offers an alternative means communication for the NVMe switch adapter – Upgrade the all files (BOOT and FIRM) without necessary system starting up to running the ArcHTTP proxy server. The nflash utility program is a DOS application, which runs in the DOS operating system. Be sure of ensuring properly to communicate between NVMe switch adapter and nflash DOS utility. Please make a bootable DOS USB devices from other Windows operating system and boot up the system from this bootable device.

- **Starting the nflash Utility**

You do not need to short any jumper cap on running nflash utility. The nflash utility provides an on-line table of contents, brief descriptions of the help sub-commands. The nflash utility can download from [https:// www.areca.com.tw](https://www.areca.com.tw). You can run the <nflash> to get more detailed information about the command usage. Typical output looks as below:

```
A:\nflash
Raid Controller Flash Utility
V1.61 2022-02-24
Command Usage:
NFLASH FileName
NFLASH FileName /cn --> n=0,1,2,3 write binary to adapter#0
FileName May Be ARC1389FIRM.BIN or ARC1389*
For ARC1389* Will Expand To ARC1389BOOT /FIRM/BIOS.BIN

A:\>nflash arc138~1.bin
Raid Controller Flash Utility
V1.61 2022-02-24
MODEL : ARC-1389-32I
MEM FE620000 FE7FF000
File ARC138~1.BIN : >>*** => Flash OK
```

# APPENDIX

---

## A-4 Upgrading Firmware Through CLI

This Command Line Interface (CLI) provides you to configure and manage the NVMe switch adapter components in Windows, Linux, FreeBSD and more environments. The CLI is useful in environments where a graphical user interface (GUI) is not available. Through the CLI, you perform firmware upgrade that you can perform with the switch storage manager GUI. The adapter has added protocol on the firmware for user to update the adapter firmware package (UEFI, BOOT and FIRM) through the utility.

To update the adapter firmware, follow the procedure below:

```
Parameter:<path=<PATH_OF_FIRMWARE_FILE>>  
Fn: Firmware Updating.  
Ex: Update Firmware And File Path Is In [C:\FW\ARC1389FIRM.BIN.]  
Command: sys updatefw path=c:\fw\arc1389firm.bin [Enter]
```

# APPENDIX

## Appendix B

### Event Notification Configurations

The adapter classifies disk array events into four levels depending on their severity. These include level 1: Urgent, level 2: Serious, level 3: Warning and level 4: Information. The level 4 covers notification events such as initialization of the adapter; Level 2 covers notification events which once have happen; Level 3 includes events which require the issuance of warning messages; Level 1 is the highest level, and covers events that need immediate attention (and action) from the administrator. The following lists sample events for each level:

#### A. Device Event

Event	Level	Meaning	Action
Device Failed(SMART)	Urgent	NVMe SMART failure	Replace NVMe SSD

#### B. Hardware Monitor Event

Event	Level	Meaning	Action
Controller Over Temperature	Urgent	Abnormally high temperature detected on adapter	Check air flow and cooling fan of the enclosure, and contact us.
Hdd Over Temperature	Urgent	Abnormally high temperature detected on NVMe	Check air flow and cooling fan of the enclosure.
Fan Failed	Urgent	Cooling Fan # failure or speed below 1700RPM	Check cooling fan of the enclosure and replace with a new one if required.
Controller Temp. Recovered	Serious	Controller temperature back tonormal level	
Hdd Temp. Recovered	Serious	NVMe temperature back tonormal level	
Raid Powered On	Warning	Switch adapterpower on	
Test Event	Urgent	Test event	
Power On With Battery Backup	Warning	Switch power on with battery backuped	
HTTP Log In	Serious	a HTTP login detected	
API Log In	Serious	a API login detected	

# APPENDIX

---

## Appendix C

### High Reliability

- **Hard Drive Failure Prediction**

In an effort to help users avoid data loss, disk manufacturers are now incorporating logic into their drives that acts as an "early warning system" for pending drive problems. This system is called SMART. The disk integrated adapter works with multiple sensors to monitor various aspects of the drive's performance, determines from this information if the drive is behaving normally or not, and makes available status information to switch adapter firmware that probes the drive and look at it.

The SMART can often predict a problem before failure occurs. The adapters will recognize a SMART error code and notify the administer of an impending hard drive failure.

### Data Protection

- **Recovery ROM**

Switch adapter firmware is stored on the flash ROM and is executed by the management processor. The firmware can also be updated through the switch adapters PCIe bus port without the need to replace any hardware chips. During the adapter firmware upgrade flash process, it is possible for a problem to occur resulting in corruption of the adapter firmware. With our Redundant Flash Image feature, the controller will revert back to the last known version of firmware and continue operating. This reduces the risk of system failure due to firmware crash.