

Thunderbolt LCD

USER Manual

Version: 1.1

Issue Date: April, 2026

WARRANTY

The information in this document is subject to change without notice. We make no warranty of any kind regarding this material, including, but not limited to, the implied warranties or merchantability and fitness for a particular purpose. Furthermore, we shall not be liable for errors contained herein or for incidental or consequential damage in connection with the furnishing, performance, or use of this material.

Contents

LCD Configuration Menu	6
1.1 Overview	6
1.2 Front Panel Touch-Control Keypad	6
1.3 LCD Configuration Menu Tree.....	8
1.4 Starting LCD Configuration Utility	9
1.5 LCD Configuration Utility Main Menu Options.....	10
1.6 Configuring Raid Sets and Volume Sets	10
1.7 Designating Drives as Hot Spares.....	11
1.8 Using Quick Volume and Raid Set Setup	11
1.9 Using Raid Set and Volume Set Functions	13
1.10 Navigation Map of the LCD For Raid Controller.....	14
1.10.1 Quick Volume And Raid Set Setup.....	15
1.10.2 Raid Set Functions.....	16
1.10.2.1 Create A New Raid Set	17
1.10.2.2 Delete Raid Set.....	17
1.10.2.3 Expand Raid Set	18
• Migrating	18
1.10.2.4 Offline Raid Set	18
1.10.2.5 Activate Incomplete RaidSet.....	19
1.10.2.6 Create Hot Spare Disk	19
1.10.2.7 Delete Hot Spare Disk	19
1.10.2.8 Display Raid Set Information	19
1.10.3 Volume Set Functions.....	20
1.10.3.1 Create Raid Volume Set	21
• Volume Name	21
• Raid Level	21
• Stripe Size	21
• Cache Mode	21
• SCSI Host	21
• SCSI ID	22
• SCSI LUN	22
• Tag Queuing	22
1.10.3.2 Delete Existed Volume Set	22
1.10.3.3 Modify Volume Set Attribute	22
1.10.3.4 Check Volume Set Consistency	23
1.10.3.5 Stop Volume Set Consistency Check.....	23
1.10.3.6 Display Volume Set Information	24

1.10.4 Physical Drive Functions	25
1.10.4.1 Display Drive Information	25
1.10.4.2 Create Pass Through Disk	26
1.10.4.3 Modify a Pass Through Disk	26
1.10.4.4 Delete Pass Through Disk.....	27
1.10.4.5 Identify The Selected Drive	27
1.10.5 Raid System Functions	27
1.10.5.1 Mute The Alert Beeper	29
1.10.5.2 Alert Beeper Setting	29
1.10.5.3 Change Password.....	29
1.10.5.4 JBOD/RAID Mode Configuration	29
1.10.5.5 Host Interface Mode	30
1.10.5.6 Raid Rebuild Priority	30
1.10.5.7 SATA NCQ Mode Support.....	30
1.10.5.8 HDD Read Ahead Cache	31
1.10.5.9 Volume Data Read Ahead.....	31
1.10.5.10 Empty HDD Slot LED Control	31
1.10.5.11 Disk Write Cache Mode	31
1.10.5.12 Disk Capacity Truncation Mode.....	31
1.10.6 HDD Power Management	32
1.10.6.1 Stagger Power On Control.....	32
1.10.6.2 Time to Low Power Idle	33
1.10.6.3 Time To Low RPM Mode	33
1.10.6.4 Time To Spin Down Idle Hdd	33
1.10.7 Ethernet Configuration	33
1.10.7.1 DHCP Function	33
1.10.7.2 Local IP Address	34
1.10.7.3 HTTP Port Number	35
1.10.7.4 Telnet Port Number	35
1.10.7.5 SMTP Port Number	35
1.10.7.6 Ethernet Address	35
1.10.8 View System Events.....	35
1.10.9 Clear All Events Buffers	36
1.10.10 Hardware Monitor Information	36
1.10.11 Show System Information.....	36

THUNDERBOLT - LCD

LCD Configuration Menu

1.1 Overview

After the hardware installation, the HDD disk drives connected to the ARC-8050 RAID storage must be configured and the volume set units initialized before they are ready to use. This can be accomplished by the Front panel touch-control keypad (ARC-1000 LCD module).

The RAID storage LCD configuration utility is a character-based utility that you can run after powering the unit. This user interfaces can access the built-in configuration and administration utility that resides in the controller's firmware. They provide complete control and management of the controller and disk arrays, eliminating the need for additional hardware or software. Use LCD Configuration Utility to:

- Create RAID set,
- Expand RAID set,
- Define volume set,
- Add physical drive,
- Modify volume set,
- Modify RAID level/stripe size,
- Define pass-through disk drives,
- Modify system function and
- Designate drives as hot spares.

The LCD display front panel function keys are the primary user interface for the RAID storage. Except for the "Firmware update", all configurations can be performed through this interface.

1.2 Front Panel Touch-Control Keypad

The front panel keypad and liquid crystal display (LCD) is the primary user interface for the RAID storage. All configuration and management of the controller and its properly connected disk arrays can be performed from this interface.

THUNDERBOLT - LCD

The front panel keypad and LCD are connected to the RAID storage to access the built-in configuration and administration utility that resides in the controller's firmware. Complete control and management of the array's physical drives and logical units can be performed from the front panel, requiring no additional hardware or software drivers for that purpose.

This technical manual provides, in quick reference form, procedures that use the built-in LCD panel to configure and operate the controller. A touch-control keypad and a liquid crystal display (LCD) mounted on the front panel of the RAID storage is the primary operational interface and monitor display for the disk array controller. This user interface controls all configuration and management functions for the RAID storage controller and for all HDDs to which it is properly connected.

The LCD provides a system of screens with areas for information, status indication, or menus. The LCD screen displays up to two lines at a time of menu items or other information.

The LCD module initial screen is as following:

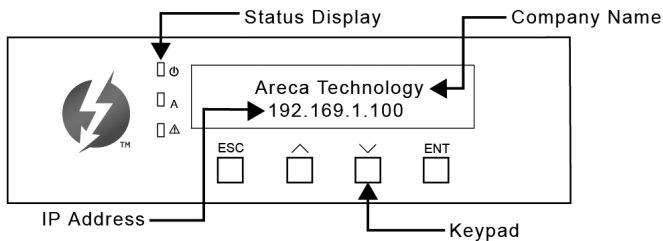

Function Key Definitions on LCD Module:

The four function keys at the bottom of the front panel perform the following functions:

Key	Function
Up Arrow	Use to scroll the cursor Upward / Rightward
Down Arrow	Use to scroll the cursor Downward / Leftward
ENT Key	Submit select icon function (Confirm a selected item)
ESC Key	Return to previous screen (Exit a selection configuration)

THUNDERBOLT - LCD

The LCD status panel informs you the disk array's current operating status at a glance. There are a variety of failure conditions that cause the RAID subsystem monitoring LED to light. Below table provides a summary of the front panel LED and RAID storage LED.

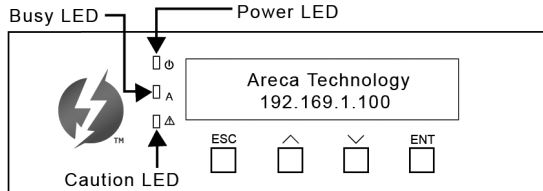

Panel LED	Normal Status	Problem Indication
1. Power LED (Green)	Solid green, when power on	Unlit, when power on
2. Busy LED (Amber)	Blinking amber during host accesses RAID storage	Unlit or never flicker
3. Caution LED (Red)	Unlit indicates that the RAID storage and all its components are operating correctly.	Solid indicates that one or more component failure/Urgent events have occurred.

1.3 LCD Configuration Menu Tree

The following is an expansion of the menus in configuration utility that can be accessed through the LCD panel.

THUNDERBOLT - LCD

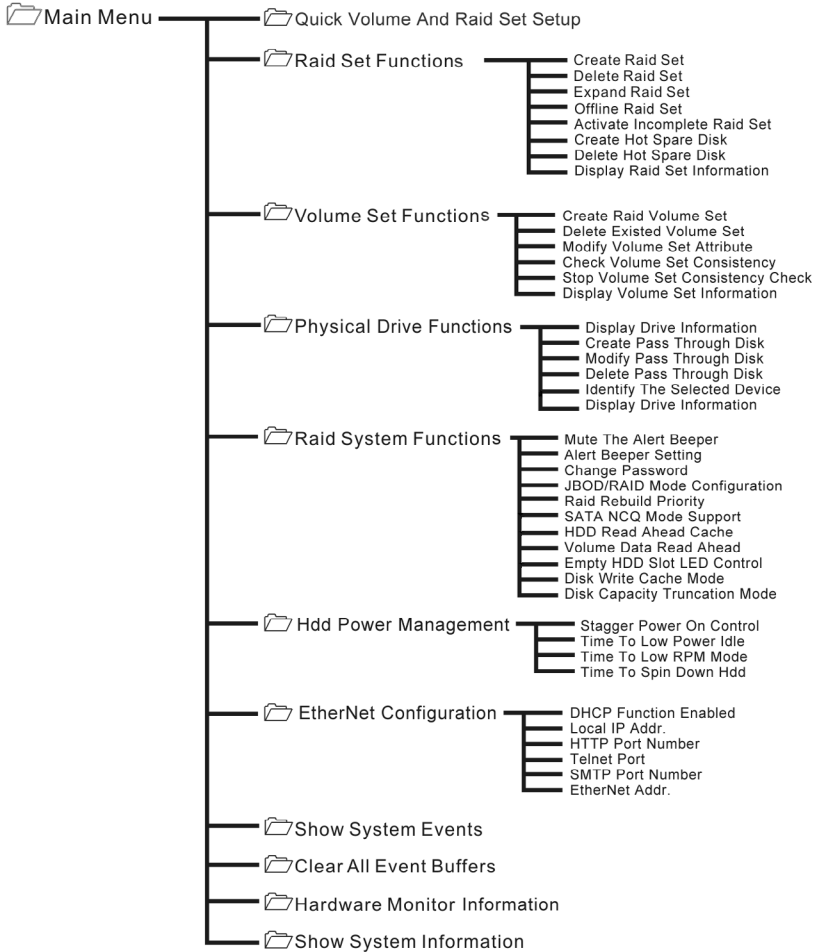

1.4 Starting LCD Configuration Utility

Use the up and down arrow buttons to move left and right and highlight a menu item. Press **ENTER** to select the highlighted item. Press the **UP/DOWN** to browse the selection. Press **ESC** to return to the previous screen.

THUNDERBOLT - LCD

1.5 LCD Configuration Utility Main Menu Options

Select an option and the related information or sub-menu items display beneath it. The sub-menus for each item are explained on the section 1.10.1. The configuration utility main menu options are:

Option	Description
Quick Volume And Raid Set Setup	Create a default configurations which are based on the number of physical disk installed
Raid Set Functions	Create a customized raid set
Volume Set Functions	Create a customized volume set
Physical Drive Functions	View individual disk information
Raid System Functions	Setting the raid system configurations
Hdd Power Management	Manage HDD power based on usage patterns
EtherNet Configuration	LAN port setting
Show System Events	Record all system events in the buffer
Call All Event Buffers	Clear all event buffer information
Hardware Monitor Information	Show all system environment status
Show System Information	View the controller information

1.6 Configuring Raid Sets and Volume Sets

You can configure raid sets and volume sets with LCD configuration utility using "Quick Volume And Raid Set Setup", "Raid Set Functions" and "Volume Set Functions" configuration method. Each configuration method requires a different level of user input. The general flow of operations for raid set and volume set configuration is:

Step	Action
1	Designate hot spares/pass-through (optional)
2	Choose a configuration method
3	Create raid set using the available physical drives
4	Define volume set using the space in the raid set
5	Initialize the volume set and use volume set in the host OS

THUNDERBOLT - LCD

1.7 Designating Drives as Hot Spares

To designate drives as hot spares, press **Enter** to enter the main menu. Press **UP/DOWN** to select the "Raid Set Functions" option and then press **Enter**. All Raid set functions will be displayed. Press **UP/DOWN** to select the "Create Hot Spare Disk" option and then press **Enter**. The first unused physical device connected to the current controller appears: Press **UP/DOWN** to scroll the unused physical devices and select the target disk to assign as a hot spare and press **Enter** to designate it as a hot spare.

1.8 Using Quick Volume and Raid Set Setup

In "Quick Volume And Raid Set Setup" Configuration, The raid set you create is associated with exactly one volume set, and you can modify the RAID level, stripe size, and capacity. Designating drives as hot spares will also combine with raid level in this setup.

The volume set default settings will be:

The default setting values can be changed after configuration is complete.

Parameter	Setting
Volume Name	Volume Set#00
SCSI Host/SCSI ID/SCSI LUN	0/0/0
Cache Mode	Write Back
Tag Queuing	Yes

Following steps below are create raid set using "Quick Volume and Raid Set Setup" Configuration:

THUNDERBOLT - LCD

Step	Action
1	Choose "Quick Volume And Raid Set Setup" from the main menu. The available RAID levels with hot spare for the current volume set drive are displayed.
2	<p>It is recommend that you drives of the same capacity in a specific array. If you use drives with different capacities in an array, all drives in the raid set will be set to the capacity of the smallest drive in the raid set. The numbers of physical drives in a specific array determines which RAID levels that can be implemented in the array.</p> <p>RAID 0 requires 1 or more physical drives. RAID 1 requires at least 2 physical drives. RAID 1+Spare requires at least 3 physical drives. RAID 10 requires at least 4 physical drives. RAID 3 requires at least 3 physical drives. RAID 5 requires at least 3 physical drives. RAID 3 +Spare requires at least 4 physical drives. RAID 5 + Spare requires at least 4 physical drives. RAID 6 requires at least 4 physical drives. RAID 6 + Spare requires at least 5 physical drives.</p> <p>Highlight the desired RAID level for the volume set and press the Enter key to confirm.</p>
3	<p>The capacity for the current volume set is entered after highlighting the desired RAID level and pressing the Enter key. The capacity for the current volume set is displayed. Use the UP/DOWN arrow keys to set the capacity of the volume set and press the Enter key to confirm. The available stripe sizes for the current volume set are then displayed.</p>
4	Use the UP/DOWN arrow keys to select the current volume set stripe size and press the Enter key to confirm. This parameter specifies the size of the stripes written to each disk in a RAID 0, 1, 5 or 6 volume set. You can set the stripe size to 4 KB, 8 KB, 16 KB, 32 KB, 64 KB, or 128 KB. A larger stripe size provides better read performance, especially when the computer preforms mostly sequential reads. However, if the computer preforms random read requests more often, choose a smaller stripe size.
5	When you are finished defining the volume set, press the Enter key to confirm the "Quick Volume And Raid Set Setup" function.
6	Foreground (Fast Completion) press Enter key to define fast initialization or selected the Background (Instant Available). In the background Initialization, the initialization proceeds as a background task, the volume set is fully accessible for system reads and writes. The operating system can instantly access to the newly created arrays without requiring a reboot and waiting the initialization complete. In fast initialization, the initialization proceeds must be completed before the volume set ready for system accesses.
7	Initialize the volume set you have just configured.
8	If you need to add additional volume set, using main menu "Create Volume Set" function.

THUNDERBOLT - LCD

1.9 Using Raid Set and Volume Set Functions

In "Raid Set Function", you can use the create raid set function to generate the new raid set. In "Volume Set Function", you can use the create volume set function to generate its associated volume set and parameters.

If the current controller has unused physical devices connected, you can choose the "Create Hot Spare" option in the "Raid Set Function" to define a global hot spare. Select this method to configure new raid sets and volume sets. This configuration option allows you to associate volume set with partial and full raid set.

Step	Action
1	To setup the Hot Spare (option), choose "RAID Set Function" from the main menu. Select the "Create Hot Spare" and press the Enter key to define the hot spare.
2	Choose "RAID Set Function" from the main menu. Select "Create RAID Set" and press the Enter key.
3	The "Select a Drive For Raid Set" window is displayed showing the SATA drives connected to the RAID storage.
4	Press the UP/DOWN arrow keys to select specific physical drives. Press the Enter key to associate the selected physical drive with the current RAID set. It is recommend that you drives of the same capacity in a specific array. If you use drives with different capacities in an array, all drives in the raid set will be set to the capacity of the smallest drive in the raid set. The numbers of physical drives in a specific array determines which RAID levels that can be implemented in the array. RAID 0 requires 1 or more physical drives. RAID 1 requires at least 2 physical drives. RAID 10 requires at least 4 physical drives. RAID 3 requires at least 3 physical drives. RAID 5 requires at least 3 physical drives. RAID 6 requires at least 4 physical drives.
5	After adding the desired physical drives to the current RAID set, press Yes to confirm the "Create Raid Set" function.
6	An "Edit The Raid Set Name" dialog box appears. Enter 1 to 15 alphanumeric characters to define a unique identifier for this new Raid set. The default raid set name will always appear as Raid Set. #. Press Enter to finish the name editing.

THUNDERBOLT - LCD

7	Press the Enter key when you are finished creating the current RAID Set. To continue defining another RAID set, repeat step 3. To begin volume set configuration, go to step 8.
8	Choose the "Volume Set Function" from the main menu. Select "Create Volume Set" and press the Enter key.
9	Choose a RAID set from the create volume from Raid set window. Press the Enter key to confirm the selection.
10	The volume set attributes screen appears: The volume set attributes screen shows the volume set default configuration value that is currently being configured. The volume set attributes are: Raid Level, Stripe Size, SCSI HOST/SCSI ID/SCSI LUN/ Cache Mode, Tagged Queuing, and Volume Name (number). All value can be changing by the user. Press the UP/DOWN to select the attributes. Press the Enter to modify each attribute of the default value. Using the UP/DOWN to select attribute value and press the Enter to accept the default value.
11	If space remains in the raid set, the next volume set can be configured. Repeat steps 8 to 10 to configure another volume set.
12	When you are finished defining the volume set, press Enter to confirm the Create function.
13	Press Enter to define fast initialization and ESC to normal initialization. The controller will begin to initialize the volume set, you have just configured. If space remains in the raid set, the next volume set can be configured. Repeat steps 8 to 13 to configure another volume set.

1.10 Navigation Map of the LCD For Raid Controller

The password option allows user to set or clear the RAID controller password protection feature. Once the password has been set, the user can only monitor and configure the raid adapter by providing the correct password. The password is used to protect the Raid box from unauthorized entry. The RAID box will check the password only when entering the main menu from the initial screen and will automatically go back to the initial screen when it does not receive any command in twenty seconds. Also RAID controller's password is default setting at 0000 by the manufacture.

THUNDERBOLT - LCD

Figure 1-10

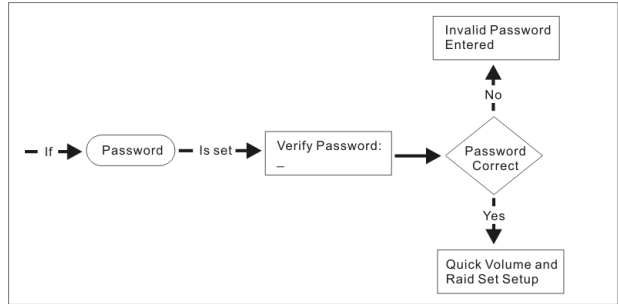

1.10.1 Quick Volume And Raid Set Setup

“Quick Volume And Raid Set Setup” is the fastest way to prepare a RAID set and volume set. It only needs a few keystrokes to complete it. Although disk drives of different capacity may be used in the raid set, it will use the smallest capacity of the disk drive as the capacity of all disk drives in the RAID set. The “Quick Volume And RAID Set Setup” option creates a RAID set with the following properties:

1. All of the physical disk drives are contained in a RAID set.
2. The RAID levels associated with hot spare, capacity, and stripe size are selected during the configuration process.
3. A single volume set is created and consumed all or a portion of the disk capacity available in this RAID set.
4. If you need to add additional volume set, using main menu “Volume Set Functions”; detailed procedure refer to this chapter section 1.10.3.1.

Figure 1-10-1

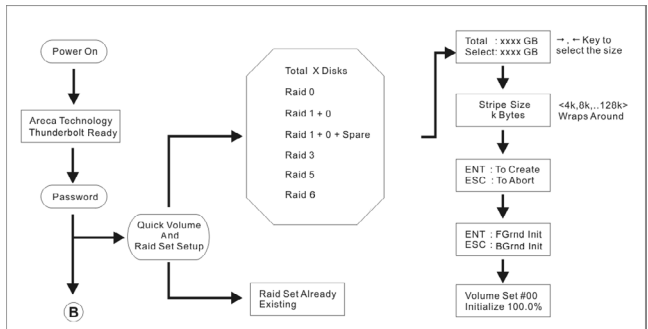

THUNDERBOLT - LCD

The total number of physical drives in a specific RAID Set determine the RAID levels that can be implemented within the RAID Set. Select "Quick Volume And Raid Set Setup" from the main menu; all possible RAID level will be displayed on the screen.

If volume capacity will exceed 2TB, Raid box will show the Greater 2 TB volume Support sub-menu.

- **No**

It keeps the volume size with max. 2TB limitation.

- **LBA 64**

This option use 16 bytes CDB instead of 10 bytes. The maximum volume capacity up to 512TB.

This option works on different OS which supports 16 bytes CDB.

- **4K Block**

It change the sector size from default 512 Bytes to 4k Bytes. the maximum volume capacity up to 16TB.

This option works under Windows platform only. And it **CAN NOT** be converted to Dynamic Disk, because 4k sector size is not a standard format.

For more over 2TB details, please download PDF file from <http://www.areca.com.tw>

1.10.2 Raid Set Functions

User manual configuration can complete control of the raid set setting, but it will take longer time to complete than the "Quick Volume And Raid Set Setup" configuration. Select the "Raid Set Function" to manually configure the raid set for the first time or deletes existing raid set and re-configure the raid set.

To enter a "Raid Set Functions", press **Enter** to enter the main menu. Press **UP/DOWN** to select the "Raid Set Functions" option and then press **Enter** to enter further submenus. All raid set submenus will be displayed.

THUNDERBOLT - LCD

Figure 1-10-2-1

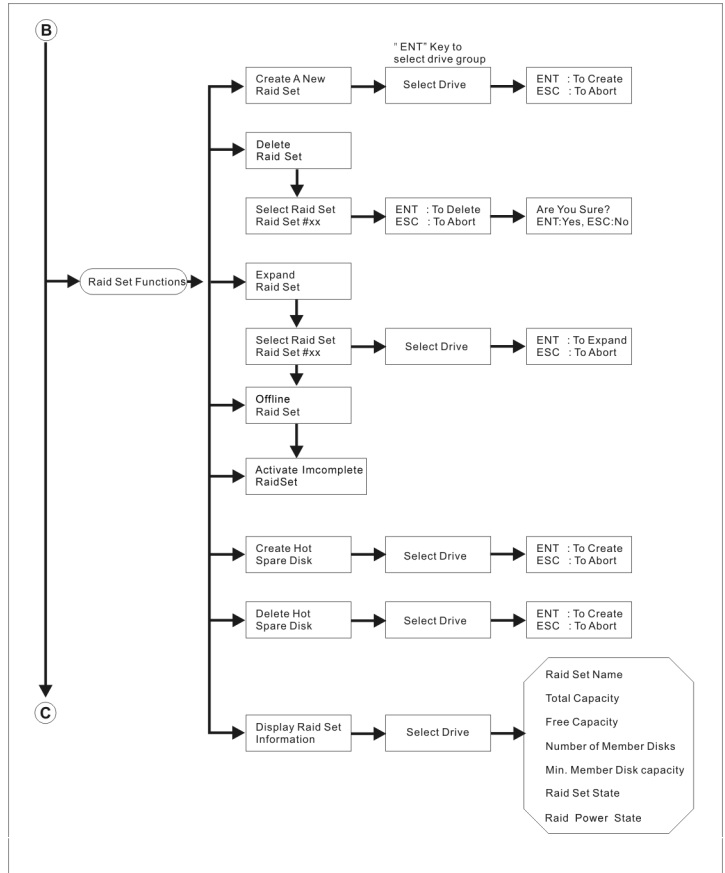

1.10.2.1 Create A New Raid Set

A "Select SATA Drive For Raid Set" window is displayed showing the SATA drives connected to the current controller. Press the **UP/DOWN** arrow keys to select specific physical drives. Press the **Enter** key to associate the selected physical drive with the current RAID Set. Repeat this step; the user can add as many disk drives as are available to a single RAID Set. When finished selecting SATA drives for Raid set, press the **Esc** key.

1.10.2.2 Delete Raid Set

Press **UP/DOWN** to choose the "Delete Raid Set" option. Us-

THUNDERBOLT - LCD

ing **UP/DOWN** to select the raid set number that user want to delete and then press **Enter** to accept the raid set number. The Confirmation screen appears, then press **Enter** to accept the delete existed raid set function. The double confirmation screen appears, then press **Yes** to make sure of the delete raid set function.

1.10.2.3 Expand Raid Set

Instead of deleting a raid set and recreating it with additional disk drives, the "Expand Raid Set" function allows the user to add disk drives to the raid set that was created.

To expand existed raid set, press **UP/DOWN** to choose the "Expand Raid Set" option. Using **UP/DOWN** to select the raid set number that user want to expand and then press **Enter** to accept the raid set number. If there is an available disk, then the Select Drive E#1Slot#x appears. Using **UP/DOWN** to select the target disk and then press **Enter** to select it. Press **Enter** to start expanding the raid set.

The new add capacity will be define one or more volume sets. Follow the instruction presented in the "Volume Set Function" to create the volume sets.

● Migrating

Migrating occurs when a disk is added to a raid set. Migration status is displayed in the raid status area of the Raid set information when a disk is added to a raid set. Migrating status is also displayed in the associated volume status area of the volume set Information when a disk is added to a raid set

Note:

1. Once the "Expand Raid Set" process has started, user can not stop it. The process must be completed.
2. If a disk drive fails during raid set expansion and a hot spare is available, an auto rebuild operation will occur after the raid set expansion completes.

1.10.2.4 Offline Raid Set

Press **UP/DOWN** buttons to choose the "Offline Raid Set"

THUNDERBOLT - LCD

option. This function is for customer being able to unmount and remount a multi-disk volume. All hdds of the selected RAID set will be put into offline state, spun down and fault LED will be in fast blinking mode.

1.10.2.5 Activate Incomplete RaidSet

When one of the disk drive is removed or loosed connection in power off state, the RAID set state will change to Incomplete State. If user wants to continue to work, when the RAID subsystem is power on. User can use the "Activate Incomplete RaidSet" option to active the RAID set. After user completed the function, the "Raid State" will change to "Degraded" mode.

1.10.2.6 Create Hot Spare Disk

When you choose the "Create Hot Spare Disk" option in the "Raid Set Functions", all unused physical devices connected to the current controller will result in the following:
Select the target disk by clicking on the LCD panel.
Press the **Enter** key to select a disk drive and press **Yes** in the "Create Hot Spare" to designate it as a hot spare.
The "Create Hot Spare" option gives you the ability to define a global hot spare.

1.10.2.7 Delete Hot Spare Disk

To delete hot spare, press **UP/DOWN** to choose the "Delete Hot Spare Disk" option. Using **UP/DOWN** to select the hot spare number that user want to delete and then press **Enter** to select it. The confirmation screens appear and press **Enter** to delete the hot spare.

1.10.2.8 Display Raid Set Information

Using **UP/DOWN** to choose the "Display Raid Set Information" option and press **Enter**. Using **UP/DOWN** to select the raid set number that user want to display. The raid set information will be displayed. It shows Raid Set Name, Number of Member Disks, Raid Set State, Total Capacity, Free Capacity, Min. Member Disk Size and Member Disk Channels.

THUNDERBOLT - LCD

1.10.3 Volume Set Functions

A volume set is seen by the host system as a single logical device. It is organized in a RAID level with one or more physical disks. RAID level refers to the level of data performance and protection of a volume set. A volume set capacity can consume all or a portion of the disk capacity available in a Raid set. Multiple volume sets can exist on a group of disks in a Raid set. Additional volume sets created in a specified Raid set will reside on all the physical disks in the Raid set. Thus each volume set on the Raid set will have its data spread evenly across all the disks in the Raid set.

To enter a "Volume Set Functions", press **Enter** to enter the main menu. Press **UP/DOWN** to select the "Volume Set Functions options" and then press **Enter** to enter further submenus. All volume set submenus will be displayed.

Figure 1-10-3-1

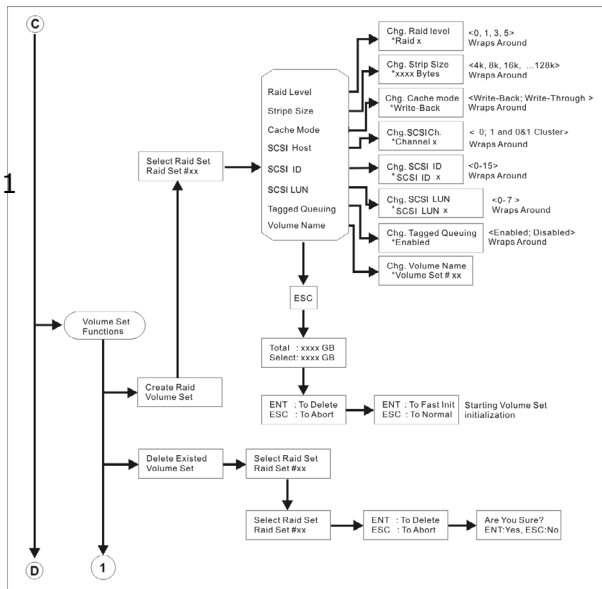

THUNDERBOLT - LCD

1.10.3.1 Create Raid Volume Set

To create a volume set, please refer to this chapter section 1.6: "Using Raid Set and Volume Set Functions". The volume set attributes screen shows the volume set default configuration value that is currently being configured.

All value can be changed by the user. Press the **UP/DOWN** to select attribute. Press the **Enter** to modify the default value. Using the **UP/DOWN** to select attribute value and press the **Enter** to accept the default value. The following is the attributes descriptions. Please refer to this chapter section 1.7 "Using Raid Set and Volume Set Functions" to complete the create volume set function.

- **Volume Name**

The default volume name will always appear as volume set. #. You can rename the volume set name providing it does not exceed the 15 characters limited.

- **Raid Level**

Set the RAID level for the volume set. Highlight Raid level and press **Enter**. The available RAID levels for the current volume set are displayed. Select a RAID level and press the **Enter** key to confirm.

- **Stripe Size**

This parameter sets the size of the segment written to each disk in a RAID 0, 1, 5 or 6 logical drive. You can set the stripe size to 4 KB, 8 KB, 16 KB, 32 KB, 64 KB, or 128 KB.

- **Cache Mode**

User can set the cache mode as Write-Through Cache or Write-Back Cache.

A larger stripe size produces better-read performance, especially if your computer does mostly sequential reads. However, if you are sure that your computer does random reads more often, select a small stripe size.

- **SCSI Host**

The RAID storage function simulates a SCSI RAID controller. The

THUNDERBOLT - LCD

host bus represents the SCSI Host channel. Using **UP/DOWN** arrow keys to choose the SCSI Host channel. A "Select SCSI Host Channel" appears; select the channel number and press the **Enter** key to confirm it.

- **SCSI ID**

Each device attached to the RAID storage, as well as the controller itself, must be assigned a unique SCSI ID number. A SCSI channel can connect up to 15 devices. It is necessary to assign a SCSI ID to each device from a list of available SCSI IDs.

- **SCSI LUN**

Each SCSI ID can support up to 8 LUNs. Most SCSI host adapter treats each LUN like a SCSI disk.

- **Tag Queuing**

The enabled option is useful for enhancing overall system performance under multi-tasking operating systems. The Command Tag (Drive Channel) function controls the SCSI command tag queuing support for each drive channel. This function should normally remain enabled. Disable this function only when using older SCSI drives that do not support command tag queuing.

1.10.3.2 Delete Existed Volume Set

Choose the "Delete Existed Volume Set" option. Using **UP/DOWN** buttons to select the RAID set number that user want to delete and press **Enter**. The confirmation screen appears, and then press **Enter** to accept the delete volume set function. The double confirmation screen appears, then press **Enter** to make sure of the delete volume set function.

1.10.3.3 Modify Volume Set Attribute

Use this option to modify volume set configuration. To modify volume set values from Raid set system function, Choose the "Volume Set Functions" menu and select the "Modify Volume Set Attribute" item, then press the **Enter** key. The "Volume Set Functions" menu will show all Raid set items. Move **UP/DOWN**

THUNDERBOLT - LCD

arrow keys to a Raid set number item, then press the **Enter** key to show all volume set items. Select the volume set from the list to be changed, press the **Enter** key to modify it.

- **Volume Growth**

Use this option to expand a raid set when a disk is added to the system. The additional capacity can be used to enlarge the volume set size or to create another volume set. The "Modify Volume set function" can support the "Volume Set Expansion" function. To expand the volume set capacity from the Raid set system function, move the **UP/DOWN** to the volume set volume capacity item and entry the capacity size. Select "Confirm The Operation" and press **Enter** to complete the action. The volume set start to expand.

- **Volume Set Migration**

Migrating occurs when a volume set is migrating from one RAID level to another, a volume set strip size changes, or when a disk is added to a raid set. Migration status is displayed in the volume state area of the "Display Volume Set Information" when one RAID level to another, a volume set stripe size changes or when a disk is added to a raid set.

1.10.3.4 Check Volume Set Consistency

Use this option to check volume set consistency. To check volume set consistency from volume set system function, press **UP/DOWN** to choose the "Check Volume Set Consistency" option. Using **UP/DOWN** to select the raid set number that user want to check and press **Enter**. Scrolling the **UP/DOWN** to select the volume set number that user want to check and press **Enter**. The confirmation screen appears, press **Enter** to start the check volume set consistency.

1.10.3.5 Stop Volume Set Consistency Check

Use this option to stop volume set consistency check. To stop volume set consistency check from volume set system function, press **UP/DOWN** to choose the "Stop Volume Set Consistency Check" option and then press **Enter** to stop the check volume set consistency.

THUNDERBOLT - LCD

Figure 1-10-3-2

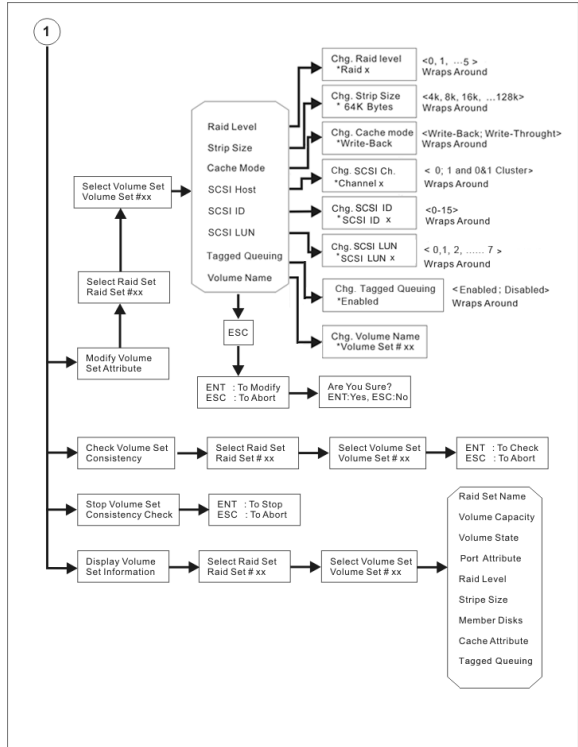

1.10.3.6 Display Volume Set Information

This option is display volume set information. To display volume set information from volume set system function, press **UP/DOWN** to choose the "Display Volume Set Information" option. Using **UP/DOWN** to select the raid set number that user wants to show and press **Enter**. Scrolling the **UP/DOWN** to select the volume set number that user want to display and press **Enter**.

The volume set attributes screen shows the volume set setting configuration value that was currently being configured. The attributes are Volume Set Name (number), Raid Set Name, Volume Capacity, Volume State, SCSI Host, SCSI ID, SCSI LUN, Raid Level, Stripe Size, Member Disk, Cache Attribute and Tag Queuing.

THUNDERBOLT - LCD

1.10.4 Physical Drive Functions

Choose this option from the main menu to select a physical disk and to perform the operations listed below. To enter a Physical drive functions, press **Enter** to enter the main menu. Press **UP/DOWN** to select the "Physical Drive Functions" option and then press **Enter** to enter further submenus. All physical drive submenus will be displayed.

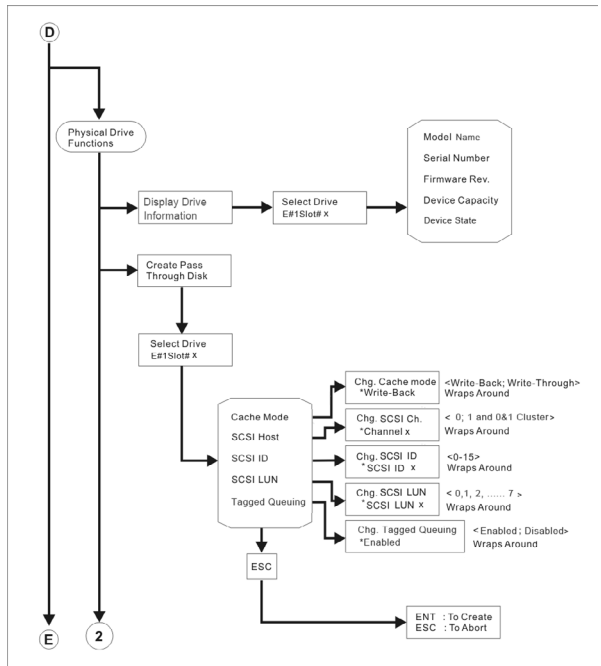

Figure 1-10-4-1

1.10.4.1 Display Drive Information

When you choose this option, the physical disks connected to the RAID storage are listed. Move the arrow key to the desired drive and press **Enter** to display drive information.

THUNDERBOLT - LCD

Figure 1-10-4-2

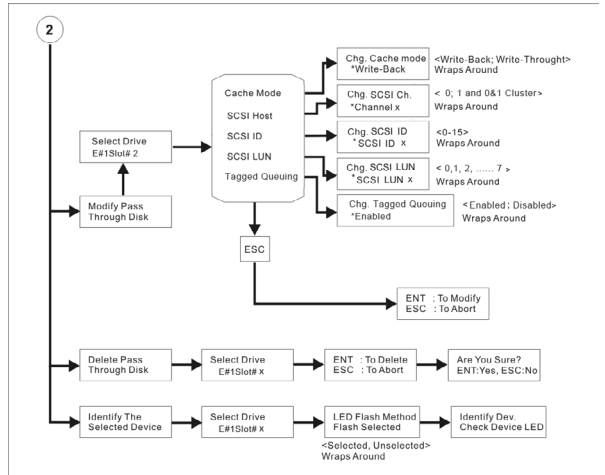

1.10.4.2 Create Pass Through Disk

Disk is no controlled by the RAID storage firmware and thus cannot be a part of a raid set. The disk is available to the operating system as an individual disk. It is typically used on a system where the operating system is on a disk not controlled by the RAID storage firmware.

Using **UP/DOWN** to choose the "Create Pass Through Disk" option and press **Enter**. Using **UP/DOWN** to select the drive IDE number that user want to create. The drive attributes will be displayed. All values can be changed by the user. Press the **UP/DOWN** to attribue and then press the **Enter** to modify the default value. Using the **UP/DOWN** to select attribute value and press the **Enter** to accept the selection value.

1.10.4.3 Modify a Pass Through Disk

To modify pass-through disk attributes from pass through drive pool, press **UP/DOWN** buttons to choose the "Modify Pass Through Disk" option, and then press **Enter**. The select drive function menu will show all pass through disk number items. Using **UP/DOWN** buttons to select the pass through disk that user wants to modify and press **Enter**. The attributes screen shows the pass through disk setting values that were currently being configured.

THUNDERBOLT - LCD

All value can be modifying by the user. Press the **UP/DOWN** arrow keys to select attribute. Press the **Enter** to modify the default value. Using the **UP/DOWN** key to select attribute value and press the **Enter** to accept the selection value. After completing the modification, press **ESC** to enter the confirmation screen and then press **Enter** to accept the "Modify Pass Through Disk" function.

1.10.4.4 Delete Pass Through Disk

To delete pass through drive from the pass through drive pool, press **UP/DOWN** to choose the "Delete Pass Through Drive" option, and then press **Enter**. The select drive function menu will show all pass through drive number items. Using **UP/DOWN** to select the pass through disk that user want to delete and press **Enter**. The delete pass through confirmation screen will appear, presses **Enter** to delete it.

1.10.4.5 Identify The Selected Drive

To prevent removing the wrong drive, the selected disk HDD LED Indicator will light for physically locating the selected disk when the "Identify The Selected Drive" is selected.

To identify selected drive from the physical drive pool, press **UP/DOWN** to choose the identify selected drive option, then press **Enter** key. The select drive function menu will show all physical drive number items. Using **UP/DOWN** to select the disk that user want to identify and press **Enter**. The selected disk HDD LED indicator will flash.

1.10.5 Raid System Functions

To enter a "Raid System Functions", press **Enter** to enter the main menu. Press **UP/DOWN** to select the "Raid System Functions" option and then press **Enter** to enter further submenus. All raid system submenus will be displayed.

THUNDERBOLT - LCD

Figure 1-10-5

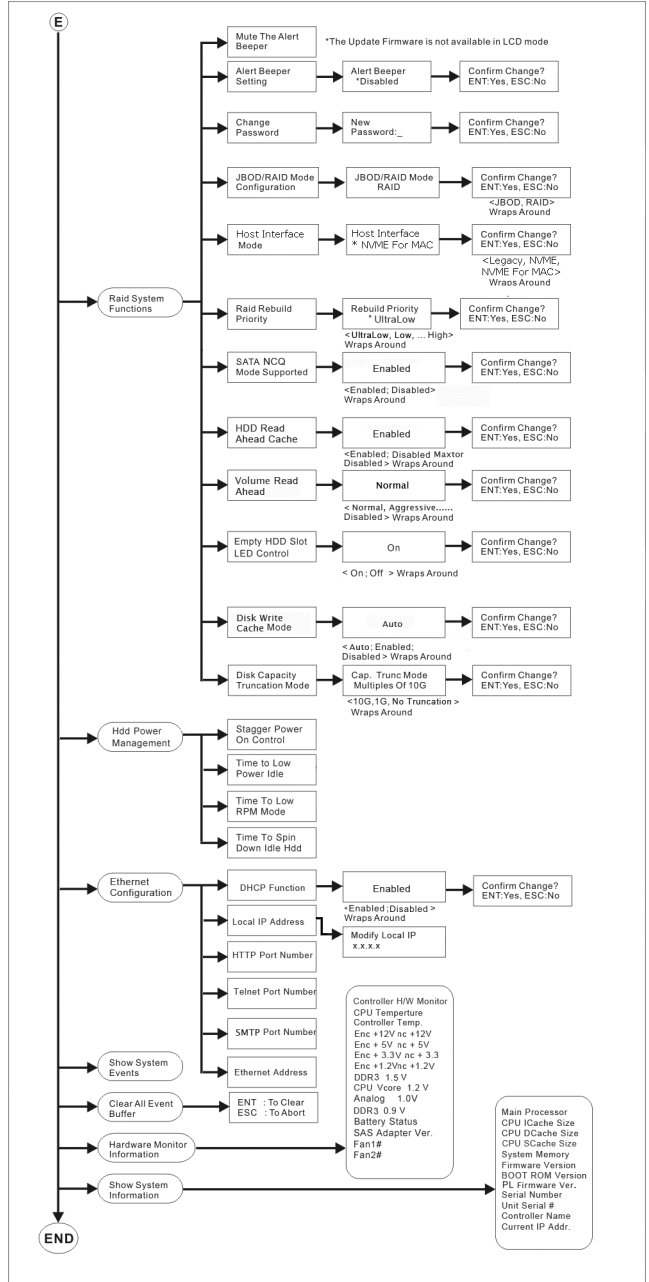

THUNDERBOLT - LCD

1.10.5.1 Mute The Alert Beeper

The Mute The Alert Beeper function item is used to control the RAID storage Beeper. Using arrow keys to Mute The Alert Beeper, then press Enter. Select the “**No**” and press Enter to turn the beeper off temporarily. The beeper will still activate on the next event.

1.10.5.2 Alert Beeper Setting

The Alert Beeper function item is used to Disabled or Enable the RAID storage alarm tone generator. Using the **UP/DOWN** to select alert beeper and then press the ENT to accept the selection. After completing the selection, the confirmation screen will be displayed and then press ENT to accept the function. Select the Disabled and press Enter to turn the beeper off temporarily. The beeper will still activate on the next event.

1.10.5.3 Change Password

To set or change the RAID storage password, press the **UP/DOWN** to select Change Password and then press the **Enter** to accept the selection. The New Password: screen appears and enter new password that user want to change. Using the **UP/DOWN** to set the password value. After completing the modification, the confirmation screen will be displayed and then press **Enter** to accept the function. To disable the password, press **Enter** only in the New Password: column. The existing password will be cleared. No password checking will occur when entering the main menu.

1.10.5.4 JBOD/RAID Mode Configuration

JBOD is an acronym for “**just a Bunch Of Disks**”. It represents a volume set that is created by the concatenation of partitions on the disk. The operating system can see all disks when the JBOD option is selected. It is necessary to delete any RAID set(s) on any disk(s) if switching from a **RAID** to a **JBOD** configuration.

THUNDERBOLT - LCD

1.10.5.5 Host Interface Mode

The "Host Interface Mode" function is used to configure RAID storage work type. "**Areca Legacy Mode**" is RAID storage work as a legacy RAID adapter, supported by Areca legacy driver. "**NVMe Mode**" is RAID storage emulated as a NVMe device, supported by system native(in-box) driver. NVMe mode means that RAID storage goes with macOS/Windows/Linux, no driver installation needed. But macOS in-box NVMe driver only supports one zoned Namespace and can't have a chance for in-band Archttp support. You can configure RAID storage as "**NVMe Mode For MAC**" and install Areca NVMe driver on macOS to support multi-volumes (multi- zoned Namespace) and in-band Archttp (3.1.0 or later version) management.

1.10.5.6 Raid Rebuild Priority

The "Raid Rebuild Priority" is a relative indication of how much time the controller devotes to a rebuild operation. The RAID subsystem allows user to choose the rebuild priority (UltraLow, Low, ... High) to balance volume set access and rebuild tasks appropriately. To set or change the RAID subsystem's RAID rebuild priority, press the **UP/DOWN** buttons to select "RAID Rebuild Priority" and press **ENT** to accept the selection. The rebuild priority selection screen appears and uses the **UP/DOWN** buttons to set the rebuild value. After completing the modification, the confirmation screen will be displayed and then press **ENT** to accept the function.

1.10.5.7 SATA NCQ Mode Support

The controller supports both SAS and SATA disk drives. The SATA NCQ allows multiple commands to be outstanding within a drive at the same time. Drives that support NCQ have an internal queue where outstanding commands can be dynamically rescheduled or re-ordered, along with the necessary tracking mechanisms for outstanding and completed portions of the workload. The RAID subsystem allows the user to select the SATA NCQ support:"Enabled" or "Disabled".

THUNDERBOLT - LCD

1.10.5.8 HDD Read Ahead Cache

Allow Read Ahead (Default: Enabled)—When enabled, the drive's read ahead cache algorithm is used, providing maximum performance under most circumstances.

1.10.5.9 Volume Data Read Ahead

The read data ahead parameter specifies the controller firmware algorithms which process the read ahead data blocks from the disk. The read ahead parameter is normal by default. To modify the value, you must know your application behavior. The default normal option satisfies the performance requirements for a typical volume. The disabled value implies no read ahead. The most efficient value for the controllers depends on your application. Aggressive read ahead is optimal for sequential access but it degrades random access.

1.10.5.10 Empty HDD Slot LED Control

From firmware version 1.39 date: 04/01/2006 or later, the firmware has added the "Empty HDD Slot LED" option to setup the Failed LED light "ON" or "OFF". When each slot has a power LED for the HDD installed identify, user can set this option to "OFF". Choose this option "ON", the failed LED light will flash red light; if no HDD installed.

1.10.5.11 Disk Write Cache Mode

User can set the "Disk Write Cache Mode" to Auto, Enabled, or Disabled. Using **UP/DOWN** to Disk Write Cache Mode, then press **Enter**. Chooses enabled increases speed, disabled increases reliability.

1.10.5.12 Disk Capacity Truncation Mode

Areca RAID storage use drive truncation so that drives from differing vendors are more likely to be able to be used as spares for each other. Drive truncation slightly decreases the usable capacity of a drive that is used in redundant units. The controller provides three truncation modes in the system configuration:

THUNDERBOLT - LCD

Multiples Of 10G, Multiples Of 1G, and Disabled.

Multiples Of 10G: If you have 120 GB drives from different vendors; chances are that the capacity varies slightly. For example, one drive might be 123.5 GB, and the other 120 GB. Areca drive Truncation mode **Multiples Of 10G** uses the same capacity for both of these drives so that one could replace the other.

Multiples Of 1G: If you have 123 GB drives from different vendors; chances are that the capacity varies slightly. For example, one drive might be 123.5 GB, and the other 123.4 GB. Areca drive Truncation mode **Multiples Of 1G** uses the same capacity for both of these drives so that one could replace the other.

Disabled: It does not truncate the capacity.

1.10.6 HDD Power Management

Areca has automated the ability to manage HDD power based on usage patterns. The "HDD Power Management" allows you to choose a "Stagger Power On Control", "Low Power Idle", "Low RPM" and completely "Spins Down Idle HDD". It is designed to reduce power consumption and heat generation on idle drives.

1.10.6.1 Stagger Power On Control

In a PC system with only one or two drives, the power can supply enough power to spin up both drives simultaneously. But in systems with more than two drives, the startup current from spinning up the drives all at once can overload the power supply, causing damage to the power supply, disk drives and other system components. This damage can be avoided by allowing the host to stagger the spin-up of the drives. The SAS/SATA drives have support stagger spin-up capabilities to boost reliability. Stagger spin-up is a very useful feature for managing multiple disk drives in a storage subsystem. It gives the host the ability to spin up the disk drives sequentially or in groups, allowing the drives to come ready at the optimum time without straining

THUNDERBOLT - LCD

the system power supply. Staggering drive spin-up in a multiple drive environment also avoids the extra cost of a power supply designed to meet short-term startup power demand as well as steady state conditions.

Areca RAID controller has included the option for customer to select the disk drives sequentially stagger power up value. The values can be selected from 0.4s to 6s per step which powers up one group of drives.

1.10.6.2 Time to Low Power Idle

This option delivers lower power consumption by automatically unloading recording heads during the setting idle time. The values can be selected "Disabled" or within the range 2 to 7 minutes.

1.10.6.3 Time To Low RPM Mode

This function can automatically spin disks at lower RPM if there have not been used during the setting idle time. The values can be selected "Disabled" or within the range 10 to 60 minutes.

1.10.6.4 Time To Spin Down Idle Hdd

This function can automatically spin down the drive if it hasn't been accessed for a certain amount of time. This value is used by the drive to determine how long to wait (with no disk activity, before turning off the spindle motor to save power). The values can be selected "Disabled" or within the range 1 to 60 minutes.

1.10.7 Ethernet Configuration

Use this feature to set the controller Ethernet port configuration. It is not necessary to create reserved disk space on any hard disk for the Ethernet port and HTTP service to function; these functions are built into the controller firmware.

1.10.7.1 DHCP Function

DHCP (Dynamic Host Configuration Protocol) allows network

THUNDERBOLT - LCD

administrators centrally manage and automate the assignment of IP (Internet Protocol) addresses on a computer network. When using the TCP/IP protocol (Internet protocol), it is necessary for a computer to have a unique IP address in order to communicate to other computer systems. Without DHCP, the IP address must be entered manually at each computer system. DHCP lets a network administrator supervise and distribute IP addresses from a central point. The purpose of DHCP is to provide the automatic (dynamic) allocation of IP client configurations for a specific time period (called a lease period) and to minimize the work necessary to administer a large IP network. To manually configure the IP address of the controller, move **UP/DOWN** arrow keys to the Main menu "Ethernet Configuration Function" item and then press the **Enter** key. The "Ethernet Configuration" menu appears on the screen. Using **UP/DOWN** arrow keys to DHCP Function item, then press **Enter** key to show the DHCP setting. Select the "Disabled" or "Enabled" option to enable or disable the DHCP function. If DHCP is disabled, it will be necessary to manually enter a static IP address that does not conflict with other devices on the network.

1.10.7.2 Local IP Address

If you intend to set up your client computers manually (no DHCP), make sure that the assigned IP address is in the same range as the default router address and that it is unique to your private network. However, it is highly recommend to use DHCP if that option is available on your network. An IP address allocation scheme will reduce the time it takes to set-up client computers and eliminate the possibilities of administrative errors and duplicate addresses. To manually configure the IP address of the controller, move **UP/DOWN** arrow keys to the Main menu Ethernet Configuration Function item and then press the **Enter** key. The Ethernet Configuration menu appears on the screen. Using **UP/DOWN** arrow keys to "Local IP Address" item, then press the **Enter** key to show the default address setting in the RAID storage. You can then reassign the static IP address of the controller.

THUNDERBOLT - LCD

1.10.7.3 HTTP Port Number

To manually configure the "HTTP Port Number" of the controller, move the cursor bar to "HTTP Port Number" item, then press the **Enter** key to show the default address setting in the RAID controller. Then You can reassign the default "HTTP Port Number" of the controller.

1.10.7.4 Telnet Port Number

To manually configure the "Telnet Port Number" of the controller, move the cursor bar to "Telnet Port Number" item, then press the **Enter** key to show the default address setting in the RAID controller. You can then reassign the default "Telnet Port Number" of the controller.

1.10.7.5 SMTP Port Number

To manually configure the "SMTP Port Number" of the controller, move the cursor bar to the main menu "Ethernet Configuration" function item and then press **Enter** key. The "Ethernet Configuration" menu appears on the screen. Move the cursor bar to "SMTP Port Number" item, then press **Enter** key to show the default address setting in the RAID controller. You can then reassign the default "SMTP Port Number" of the controller.

1.10.7.6 Ethernet Address

A MAC address stands for "Media Access Control" address and is unique to every single ethernet device. On an Ethernet LAN, it's the same as your Ethernet address. When you're connected to a local network from the RAID storage Ethernet port, a correspondence table relates your IP address to the RAID storage's physical (MAC) address on the LAN.

1.10.8 View System Events

To view the RAID storage's information, move **UP/DOWN** arrow keys to the main menu and select the "View System Events" link, then press the **Enter** key. The RAID storage's events information appear.

THUNDERBOLT - LCD

1.10.9 Clear All Events Buffers

Use this feature to clear the entire events buffer.

1.10.10 Hardware Monitor Information

To view the RAID storage's hardware monitor information, move **UP/DOWN** arrow keys to the main menu and press **Enter**. The Hardware Information will be displayed.

The Hardware Monitor Information provides the temperature and fan speed (I/O Processor fan) of the RAID storage.

1.10.11 Show System Information

Choose this option to display Main processor, CPU Instruction cache and data cache size, firmware version, serial number, controller model name, and the cache memory size. To check the system information, move **UP/DOWN** arrow keys to system information item, then press **Enter** key. All relevant information will be displayed.